

ERDC/CERL TR-01-63

Construction Engineering
Research Laboratory



**US Army Corps
of Engineers®**
Engineer Research and
Development Center

This paper was uploaded and is hosted by: Richard Hourigan, Inc. and TheWaterTreatmentStore.com. For Special Deals on all of your Water Treatment needs, visit: www.TheWaterTreatmentStore.com by CLICKING HERE.

Demonstration and Evaluation of Magnetic Descalers

Kent W. Smothers, Charles D. Curtiss, Brian T. Gard,
Robert H. Strauss, and Vincent F. Hock

September 2001

Foreword

This study was conducted under Operations and Maintenance, Army; Work Unit F88, "Evaluation of Magnetic/Electrostatic Water Treatment Devices" for the U.S. Army Center for Public Works (USACPW), which more recently has been reorganized into the Directorate of Military Programs, Headquarters, U.S. Army Corps of Engineers (HQUSACE). The technical monitors were Nelson Labbe and Malcolm McLeod, CEMP-RI.

This field test was performed at the Rock Island Arsenal (RIA) Heating Plant, Rock Island, IL. Special appreciation is owed to the RIA Points of Contact (POCs) and their contractor. This project could not have concluded successfully without the help and cooperation of the following individuals: RIA Directorate of Public Works (DPW) POCs Jay Richter, Chuck Swynenberg, and Dave Osborn, SMARI-PW; and Rock Island Integrated Services (Heating Plant) POC Doug Leyendecker.

The work was performed by the Materials and Structures Branch (CF-M) of the Facilities Division (CF), Construction Engineering Research Laboratory (CERL). The CERL principal investigator was Vincent F. Hock. Martin J. Savoie is Chief, CEERD-CF-M, and L. Michael Golish is Chief, CEERD-CF. The Acting Technical Director of the Facility Acquisition and Revitalization business area is Dr. Paul A. Howdyshell. The Acting Director of CERL is William D. Goran. The CERL technical editor was William J. Wolfe, Technical Resources.

CERL is an element of the U.S. Army Engineer Research and Development Center (ERDC), U.S. Army Corps of Engineers. The Director of ERDC is Dr. James R. Houston and the Commander is COL James S. Weller.

DISCLAIMER

The contents of this report are not to be used for advertising, publication, or promotional purposes. Citation of trade names does not constitute an official endorsement or approval of the use of such commercial products. All product names and trademarks cited are the property of their respective owners.

The findings of this report are not to be construed as an official Department of the Army position unless so designated by other authorized documents.

DESTROY THIS REPORT WHEN IT IS NO LONGER NEEDED. DO NOT RETURN IT TO THE ORIGINATOR.

Contents

Foreword.....	2
List of Figures and Tables	4
1 Introduction.....	7
Background.....	7
Objective.....	8
Approach	8
Mode of Technology Transfer	9
Units of Weight and Measure	9
2 Literature Search.....	10
3 Test Procedure	13
4 Test Results.....	24
5 Conclusions	34
Bibliography.....	35
Appendix A: Field Test Work Plan Transmittal Letters.....	41
Appendix B: Field Test Work Plan	45
Appendix C: Comments and Responses to the Field Test Work Plan	73
Appendix D: Operational Data	85
CERL Distribution	104
Report Documentation Page.....	105

List of Figures and Tables

Figures

1	Schematic of the test apparatus	14
2	Test apparatus before installation	15
3	Test apparatus after installation	16
4	Descal-A-Matic and Aqua Magnetic devices	17
5	Ener-Tec device	18
6	Temperature gauges, flow meters, and control valves	18
7	Corrosion coupons before cleaning	19
8	Corrosion coupons after cleaning	20
9	Restricted opening — flowmeter.....	21
10	Flowmeter with scale	21
11	Heat exchanger segments.....	22
12	Temperature change heat exchanger #1	25
13	Temperature change heat exchanger #2.....	26
14	Temperature change, heat exchanger #3.....	26
15	XRD pattern comparison.....	28
16	XRD pattern overlay.....	29
17	Descal-A-Matic device XRD patterns	29
18	Aqua Magnetic device XRD pattern.....	30
19	EnerTec device XRD pattern	30
20	Descal-A-Matic device control XRD pattern	31
21	Aqua Magnetic device control XRD pattern.....	31
22	EnerTec device control XRD pattern.....	32
23	Aragonite reference peaks.....	32
24	Calcite (magnesian) PDF card #43-0697	33

Tables

D1	Magnetic/electrolytic/electronic devices	86
D2	Rock Island Arsenal cold distribution.....	88

D3	Daily operational log sheets.....	89
D4	Water analyses (09 September 1999).....	96
D5	Water sample analyses (22 September 1099)	97
D6	Water sample analyses (01 October 1999)	98
D7	Water sample analyses (08 October 1999)	99
D8	Water sample analyses (15 October 1999)	100
D9	Water sample analyses (11 November 1999).....	101
D10	Corrosion coupon data.....	102
D11	Total scale removed	102
D12	Calcium/magnesium ratio	103

1 Introduction

Background

Mineral scale formation in water distribution piping impedes flow, resulting in pressure and volume reduction, and increasing operational costs. Chemical cleaning is both costly and time consuming. Using chemicals to clean potable water systems also poses some health concerns. Alternatives to the use of chemicals or ion exchange equipment* to prevent scale formation have been developed. These alternatives are designed to use electric or magnetic fields to change chemical or physical conditions in the water to perform one or all of the following functions: prevent mineral scale buildup, remove existing scale, inhibit corrosion, and control the growth of algae and bacteria.

The effectiveness of magnetic/electrostatic devices to perform these tasks has been the subject of some debate. In 1984, Construction Engineering Research Laboratory (CERL) was commissioned to evaluate magnetic devices. The study concluded that the tested magnetic devices were unable to control corrosion and/or mineral scale formation in both heating and cooling applications (Lawrence 1984). In 1996, CERL again evaluated literature supplied by one magnetic treatment device, and found no compelling technical evidence to support the company's claims.

However, some literature has reported on laboratory experiments that have shown some positive effects of magnetic fields used to control corrosion. In light of this activity, the Department of Energy Federal Energy Management Program issued a publication supporting the need for an unbiased evaluation of current commercial magnetic and electrostatic water treatment devices. A similar study was conducted at Tyndall AFB in Florida, but the results were insufficient to evaluate the performance of such devices.

* Ion (cation) exchange units operated in the sodium cycle are more commonly referred to as "water softeners."

Note that this (current and precious) work focused on the ability of magnetic devices to *prevent* scale buildup, and did not test the technology's ability to treat accumulated scale, as the term "descaler" might imply. While the manufacturers of magnetic devices describe their products as "descalers," this study uses the word solely in a denotational (not a descriptive) sense.

Objective

The objective of this work is to conduct a field test of the performance of magnetic devices. The results will be used to evaluate whether or not the specific tested devices were effective in preventing mineral scale formation in this study.

Approach

1. A literature search was done to identify key test parameters and operational constraints.
2. A "Work Plan" was written and sent for review and comment to the magnetic equipment manufacturers, and to the study's sponsoring and monitoring agencies. (Appendix A includes a reproduction of the transmittal letters and Appendix B includes the full text of the Work Plan, and of later amendments to the Plan.)
3. All comments were addressed. Written responses to comments were returned to their corresponding reviewers. (Appendix C includes reproductions of the comments and responses.)
4. A test apparatus was constructed at CERL facilities in Champaign, IL and transported to the Rock Island Arsenal Steam Plant for final installation and balancing prior to the test.
5. The test apparatus was used to test two magnetic devices and one electronic device against a control at the Steam Plant at Rock Island Arsenal, IL using Rock Island Arsenal Water Treatment Plant (WTP) supply.
6. Potable water samples were collected before entering the test apparatus, and after it left each of the three heat exchanger assemblies (both treated and control tubes).
7. Visual inspection was made of each heat exchanger and test coupon. Photographs were taken to record and detail the results.
8. Mineral scale that formed was removed, weighed, and analyzed. Analysis was done on a digested sample by Inductively Coupled Plasma Atomic Emission

Spectrometry (ICP-AES) to detect metal components, and by X-ray Diffraction to identify the crystalline structure of the deposit.

9. Results of the analyses were recorded, and conclusions were drawn based on the performance of the tested devices against a control.
10. The results of the study were peer-reviewed by technical experts representing academia, industry, government, and professional associations.

Mode of Technology Transfer

The results of this study will be made available through publication to the World Wide Web (WWW) at URL:

<http://www.cecer.army.mil>

Units of Weight and Measure

U.S. standard units of measure are used throughout this report. A table of conversion factors for Standard International (SI) units is provided below.

SI conversion factors		
1 in.	=	2.54 cm
1 ft	=	0.305 m
1 yd	=	0.9144 m
1 sq in.	=	6.452 cm ²
1 sq ft	=	0.093 m ²
1 sq yd	=	0.836 m ²
1 cu in.	=	16.39 cm ³
1 cu ft	=	0.028 m ³
1 cu yd	=	0.764 m ³
1 gal	=	3.78 L
1 lb	=	0.453 kg
1 kip	=	453 kg
1 psi	=	6.89 kPa
°F	=	(°C x 1.8) + 32

2 Literature Search

Before initiation of the test of the magnetic/electrostatic water treatment devices, a complete literature search was done to identify key test parameters and operational constraints. The Bibliography to this report (p 35) lists the results of the literature search. Appendix D to this report (Table C1) also lists all the devices found in product literature reviewed over the years. The table also provides a reference to the principle of operation proposed by the manufacturer.

Many types of nonchemical water treatment devices are widely accepted within the engineering community for being predictably effective in a given application and set of operating conditions (NACE 1998). These devices include technologies such as filters, separators, deaerators, reverse osmosis, cathodic protection, and electro-dialysis (among others). These devices all perform in a predictable and reliable fashion under a given set of conditions. The principles on which they operate are well understood and can be easily explained. Under a given set of circumstances, their performance can be accurately gauged before they are selected for a specific application. However, the same cannot be said about catalytic, electrostatic, electrolytic, electronic, and magnetic water treatment devices. There is a great deal of controversy concerning their effectiveness, and the explanation for how they actually work changes with time and between different manufacturers of the same type of device.

Respected and recognized leaders in both the scientific and consulting engineering community have long expressed skepticism regarding the claims of devices such as those listed in Table D1. Herbert H. Uhlig, longtime chairman of the highly respected Corrosion Laboratory in the Department of Metallurgy at the Massachusetts Institute of Technology, was one of the first members of the scientific community to address the issue. He wrote several editorial style papers (Eliassen and Uhlig 1952; Uhlig 1952) in the 1950s that dismissed these devices for being based on unscientific principles. This sentiment continues to the present day, and has more recently been echoed by respected consulting engineers who have encountered field installations of these devices (Dromgoole and Forbes 1979; Wilkes and Baum 1979; Puckorius 1981). Authors of books on corrosion engineering (Fontana and Greene 1967) and corrosion control (Rosa 1985; Lane 1993) consistently admonish consumers to regard any of these products with extreme caution.

Many papers have been published based on actual field trials and laboratory tests of various devices that claim to operate based on magnetic, electrolytic, electrostatic, catalytic, and other principles. These studies found that these devices have demonstrated little or no positive effects under controlled conditions. The first such device to generate widespread discussion was the EVIS unit, which claimed to operate on “catalytic” principles. This product was marketed in the 1950s, and generated a great deal of publicity. The device advertised that it catalyzed the “colloidal activity” of water to prevent scale and corrosion. Some pamphlets distributed by the company even claimed that EVIS-ized water promoted enhanced plant growth. The notoriety of this case generated considerable interest and research that largely discredited the performance claims of the manufacturer (Foster 1952; Eliassen and Skrinde 1957). The EVIS unit was ultimately withdrawn from the market.

Since that time, numerous studies conducted by consulting engineering firms and government research institutions involving field trials of electrostatic and magnetic devices have disputed the manufacturers performance claims (Welder and Partridge 1954; Meckler 1974; Dromgoole and Forbes 1979; Lawrence 1984). Several laboratory studies have reported that magnetic devices have little or no positive impact on the control of scale and corrosion (Lawrence 1984; Limpert and Raber 1985; Alleman 1985). Katz has done a number of studies to determine if magnetic fields may affect iron particles in solution that could act as nucleation sites for calcite formation (Katz 1988; Herzog et al. 1989; Katz et al. 1993; Takasaki, Parsiegla, and Katz 1994). However, he found no positive effect of magnet water treatment devices on this process. In one study, Coetzze hypothesized that it was actually the dissolution of zinc from a device that produced the positive effect attributed to the magnetic field (Coetzze et al. 1996). Some U.S. states and Canadian provinces have either banned the sale of some devices entirely or issued consumer alerts stating the devices do not work (State of Utah [Giani 1995]).

However, many people remain convinced that these devices do work. During the last several years, many articles have related laboratory and field studies supporting the efficacy of these devices for mineral scale control. Most of these propose some theory that explains the performance of the unit in question. The literature reports several field studies (Klassen 1968; Kvajic and Milosevic-Kvajic 1979; Martynova 1980; Grutsch and McClintock 1984; Raisen 1984). Of these, probably the one most cited is the paper by Grutsch and McClintock of Amoco Oil Company. Note that the use of magnetic water treatment devices at Amoco facilities was stopped soon after that paper was presented. The company has effectively distanced itself from the results indicated in the paper. Still, university professors or other researchers have published several studies supporting

the claims of magnetic or electronic units (Reimers et al. 1980; Busch 1984; Busch et al. 1984; Higashitani et al. 1993; Wang et al. 1997; Cho et al. 1997).

There obviously remains a great deal of disagreement over the effectiveness of magnetic, electrostatic, electrolytic, and electronic water treatment devices. The purpose of this study is not to resolve the debate, but to determine the effectiveness of specific devices in controlling mineral scale formation under operating conditions typical of hot water distribution systems in institutional systems.

3 Test Procedure

Two magnetic (Descal-A-Matic and Aqua Magnetic) and one electronic device (Ener Tec) were each tested against a control at the Rock Island Arsenal Steam Plant using Rock Island Arsenal Water Treatment Plant (WTP) supply. Descal-A-Matic claims to work by “imparting to the water and salt molecules additional magnetic energy, establishing a single magnetic field direction, upsetting the harmony of crystallization and breaking the intramolecular cohesion.” Aqua Magnetics does not claim to fully understand the mechanism, but postulates the scale reduction may be brought about by molecules being “polarized” in such a way that they do not react in solution. Ener Tec literature states that it is a Linear Kinetic Cell that “causes the net charge on the charge particle to be increased ... increasing the physiosorption, adsorption rate, and strength of bond.”

The magnetically-treated or electronically-treated potable water was heated to approximately 140 °F. The heat was supplied by a small steam shell and tube heat exchanger using available base steam supply at the heating plant. Corrosion was measured using test coupons that were placed at the beginning of the loop, before each of the three descaling devices, and after heating to 140 °F. Each heat exchanger contained a treated heat exchanger tube and a control, nontreated heat exchanger tube. The test heat exchangers were designed for easy disassembly for evaluation of scale formation on completion of the study. These two-tube heat exchangers have been used to evaluate scale inhibition in cooling systems for many years. (They are identical to the ones referenced in National Association of Corrosion Engineers (NACE) Standard RP 0189-95, “On-Line Monitoring of Cooling Waters.”) The test was conducted for 60 days.

The test apparatus (**Figure 1**) was constructed on-site at CERL facilities in Champaign, IL and transported to the Rock Island Arsenal Steam Plant for final installation and balancing prior to the test. For ease of transport and installation, the test apparatus was constructed on a single piece of plywood. Potable water lines were CPVC pipe and fittings, and steam/condensate lines were mild steel. The copper tube used for the heat exchanger tubes was $\frac{5}{8}$ in. The steam lines, valves, the steam trap, and condensate line were $\frac{1}{2}$ in., and the steam connections to the heat exchangers were $\frac{3}{8}$ in. Globe valves were installed in the steam line before each heat exchanger were used for modulating steam flow to regulate temperature. There was a temperature gauge in the incoming potable water and on both the test and control lines of each of the three heat exchangers.

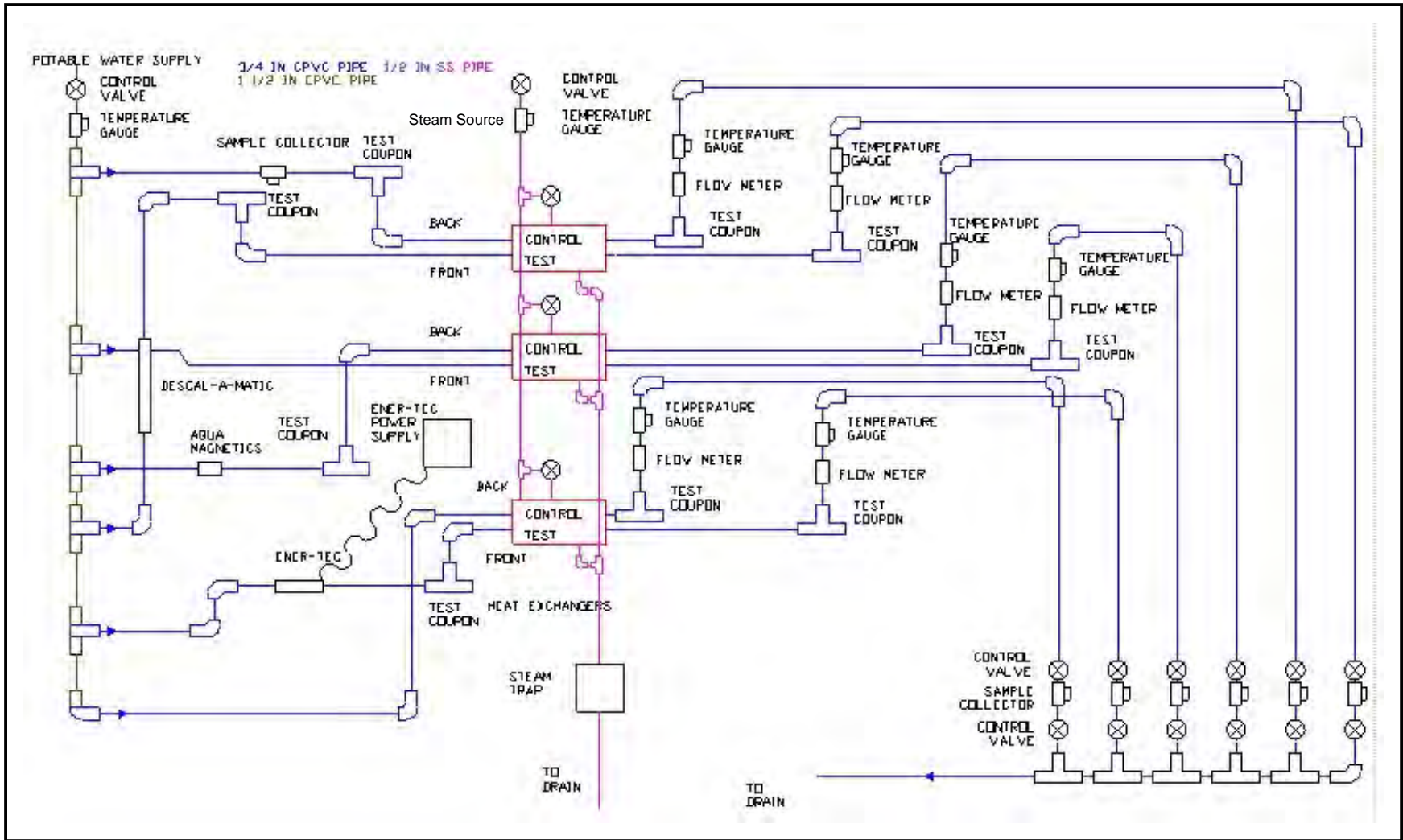

Figure 1. Schematic of the test apparatus.

Each water line was controlled by an individual CPVC globe valve to regulate water flow at 2 gal per minute (GPM) as measured by the in-line flowmeters. These flowmeters and globe valves were located downstream from the heat exchangers. A pressure gauge was installed in the steam supply line. The steam pressure varied from a low of 106 psig to a high of 128 psig, but was usually between 118 and 126 psig. The condensate and hot water effluent were routed to waste for the duration of the study. There was a floor drain directly behind the test apparatus that was used for this purpose. Photographs of the actual test apparatus construction can be found in **Figures 2 to 6**.

The Rock Island Arsenal Water Treatment Plant supplies lime softened Mississippi river water for the base supply. While there were small variances in water quality, the overall quality was very consistent for the duration of the test with the exception of temperature (Table D2). Each individual heat exchanger was controlled to try to maintain the same potable water flow rate (2 gpm) and temperature (140 °F) throughout the test procedure. Scale formation during the test did not allow us to maintain the desired temperature. However, the device and control tubes for each individual heat exchanger were maintained at the same flow rate and with the maximum steam flow to attempt to achieve the desired temperature. The operating information was recorded on a daily log sheet (Table D3) supplied to the water plant operators that monitored the test apparatus and made any necessary adjustments.

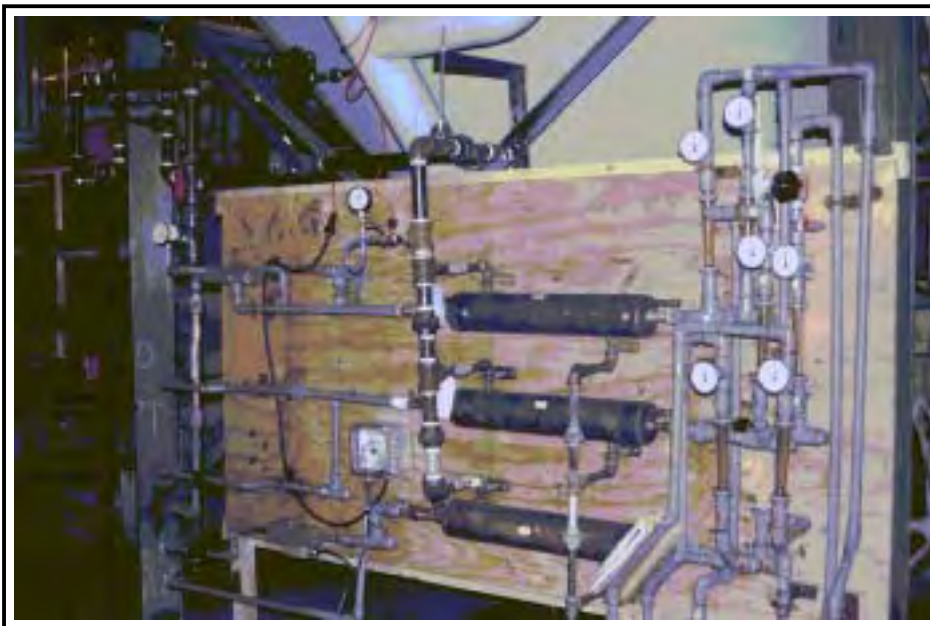

Figure 2. Test apparatus before installation.

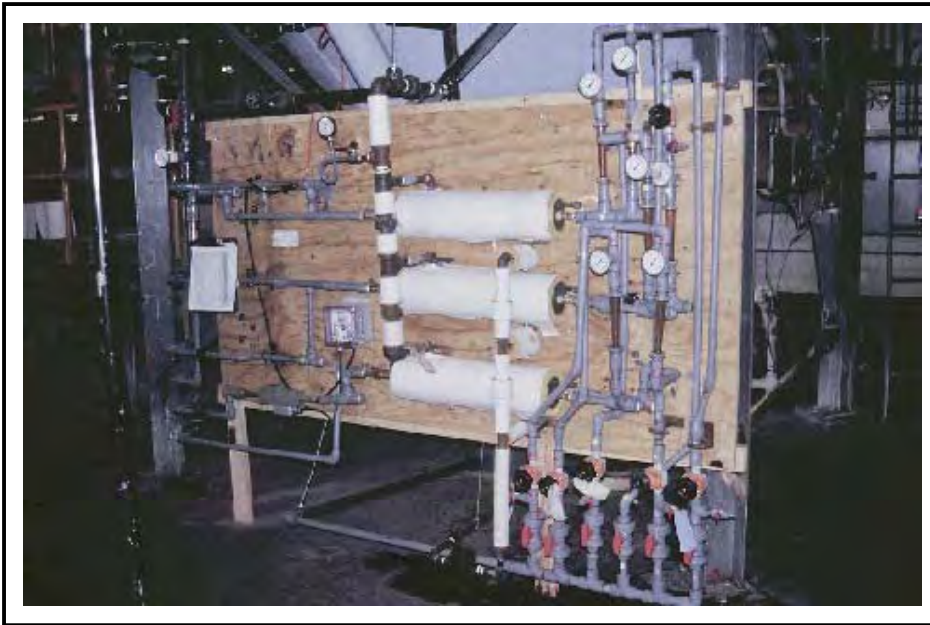

Figure 3. Test apparatus after installation.

There was one change in operating procedures during the study. The Rock Island Arsenal Water Treatment Plant only produces and pumps water from 8:00 a.m. until 4:00 p.m. daily. The system pressure is supplied by the overhead storage tank during the evening and overnight. Since there is change in pressure at this time, we originally instituted a shutdown of the steam supply to the test apparatus from 4:00 p.m. until 6:00 p.m. daily to allow the pressure to stabilize and prevent overheating the loop. We noted that scale flakes could be seen on start-up, and decided a better course of action would be to simply increase flow for those 2 hours rather starting and stopping the steam supply. This reduced the thermal shock to the system.

During the course of the study, potable water samples were collected before entering the test apparatus, and after it left each of the three heat exchanger assemblies (both treated and control tubes). On completion of the test, visual inspection was made of each heat exchanger and test coupon. Photographs (Figures 7 to 11) were taken to detail the results. Mineral scale that formed was removed, weighed, and analyzed. Analysis was conducted on a digested sample by Inductively Coupled Plasma Atomic Emission Spectrometry (ICP-AES) to detect metal components, and by X-ray Diffraction to identify the crystalline structure of the deposit. This was of particular interest for analysis of the calcium salts precipitated, since many magnetic device manufacturers claim formation of aragonite instead of calcite as a key to their effectiveness in reducing scale formation on heat exchange surfaces. Aragonite and calcite are different crystalline forms of the same chemical compound, calcium carbonate (CaCO_3).

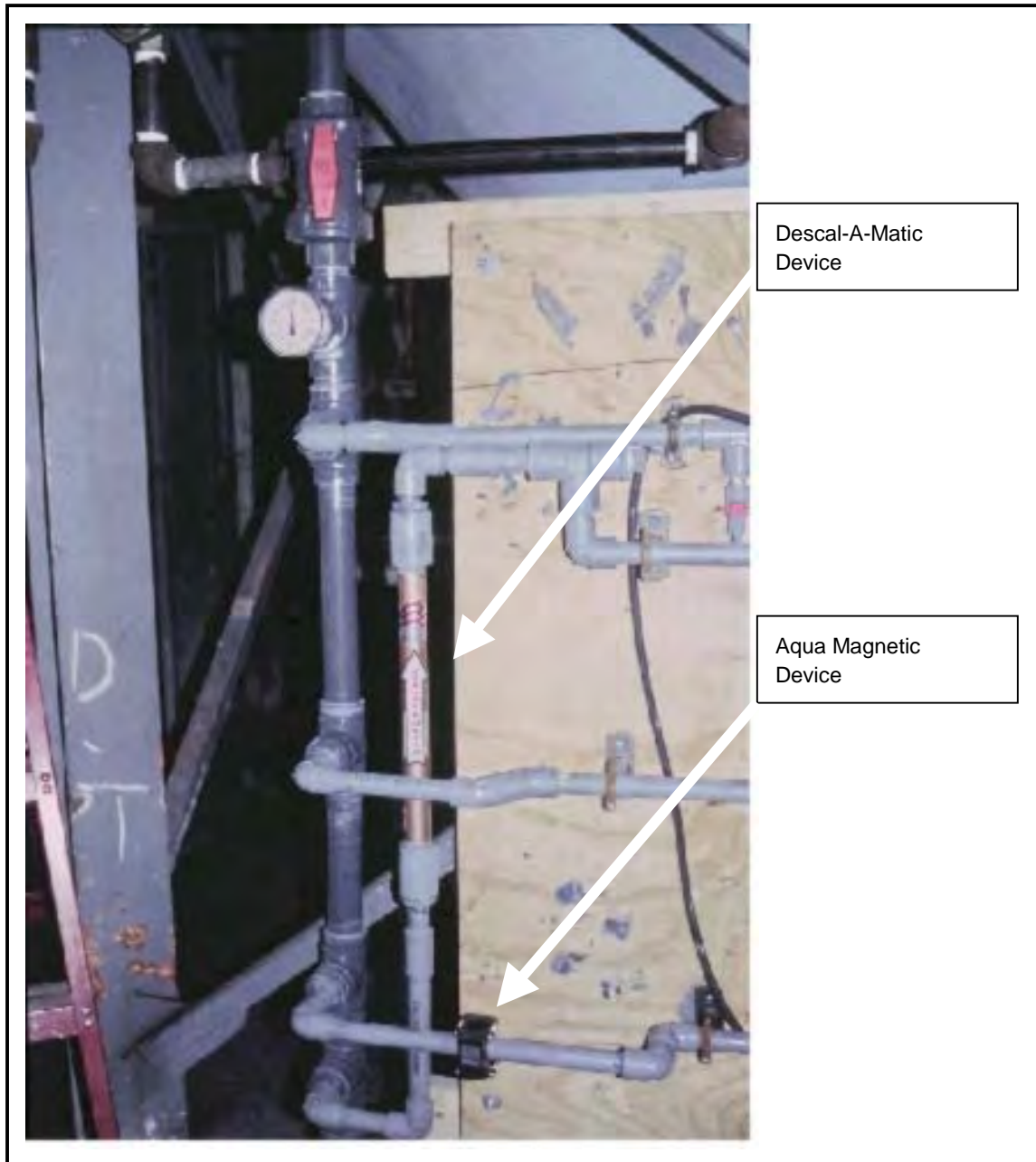

Figure 4. Descal-A-Matic and Aqua Magnetic devices.

The ICP-AES analysis “consists of a flowing stream of gas ionized by an applied radio frequency field typically oscillating at 27.1 MHz.” This field is inductively coupled to the ionized gas by a water-cooled coil surrounding a quartz “torch” that supports and confines the plasma. A sample aerosol is generated in an appropriate nebulizer and spray chamber and is carried into the plasma through an injector tube located within the torch. The sample aerosol is injected directly into the ICP, subjecting the constituent atoms to temperatures of about 6000 to 8000 °K. Because this results in almost complete dissociation of the molecules, significant reduction in chemical interferences is achieved.

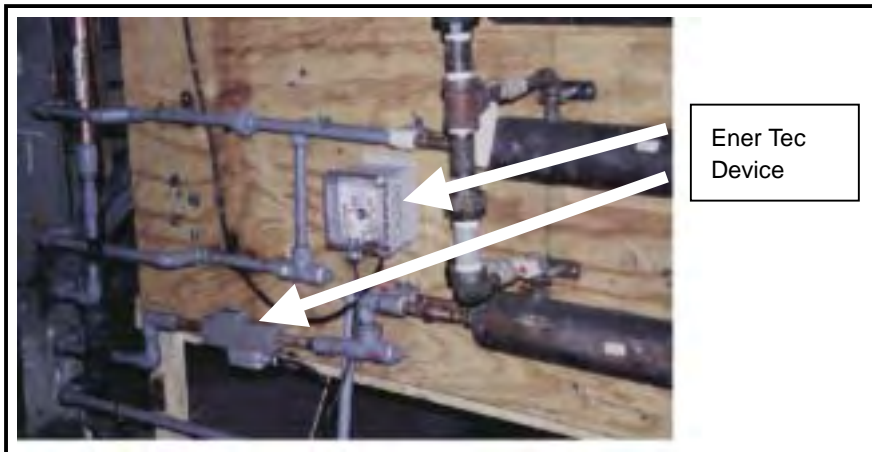

Figure 5. Ener-Tec device.

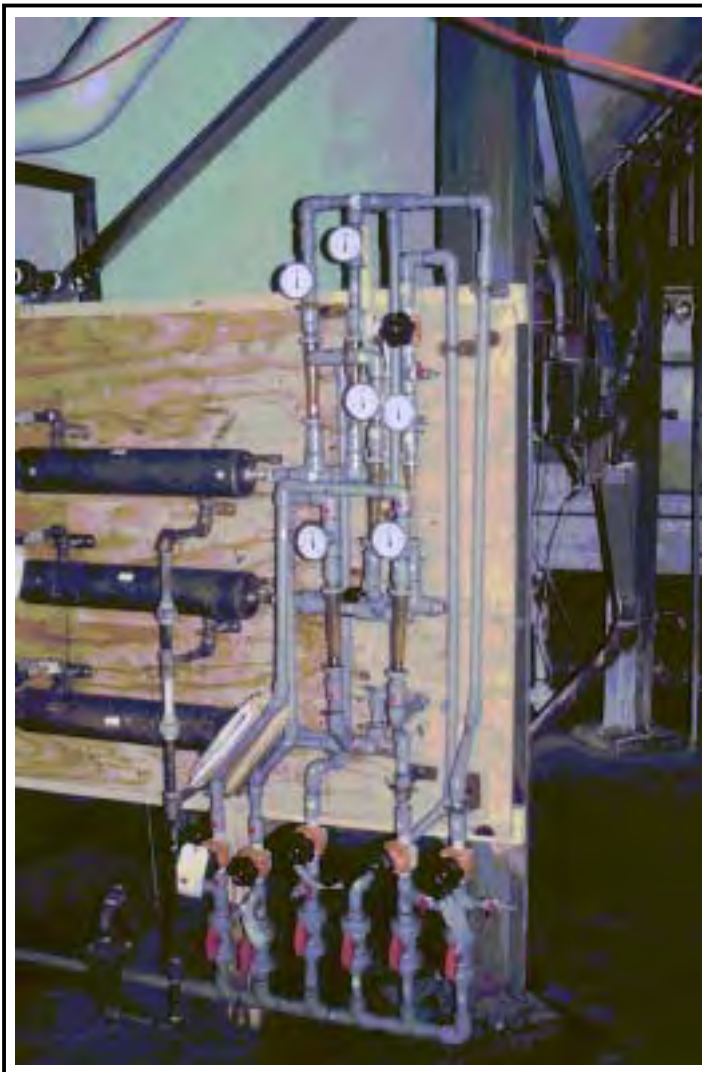

Figure 6. Temperature gauges, flow meters, and control valves.

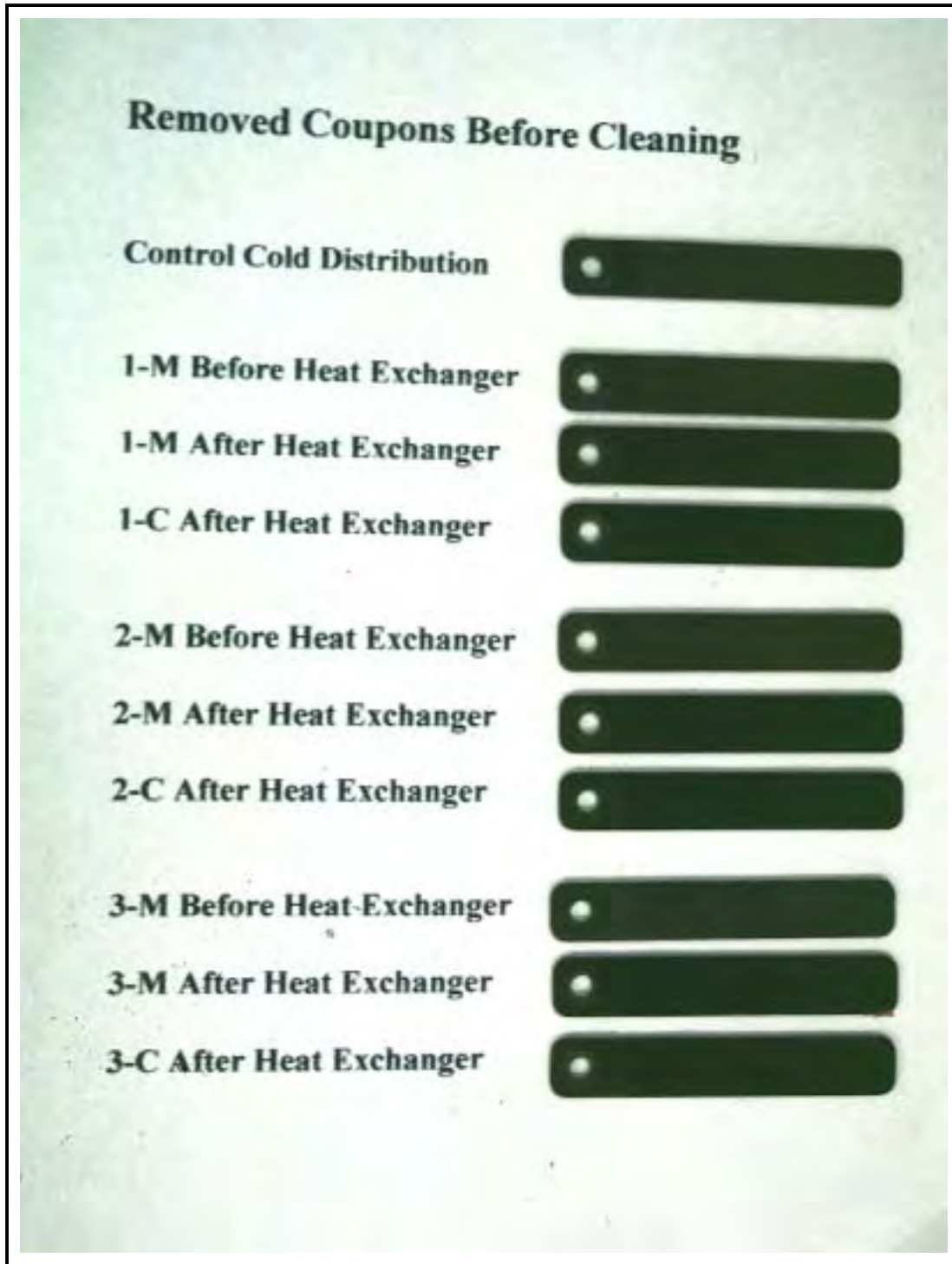

Figure 7. Corrosion coupons before cleaning.

The high temperature of the plasma excites atomic emission efficiently. Ionization of a high percentage of atoms produces ionic emission spectra. The ICP provides an optically “thin” source that is not subject to self-absorption except at very high concentrations. Thus linear dynamic ranges of four to six orders of magnitude are observed for many elements” (*Standard Methods* 1989).



Figure 8. Corrosion coupons after cleaning.



Figure 9. Restricted opening — flowmeter.



Figure 10. Flowmeter with scale.

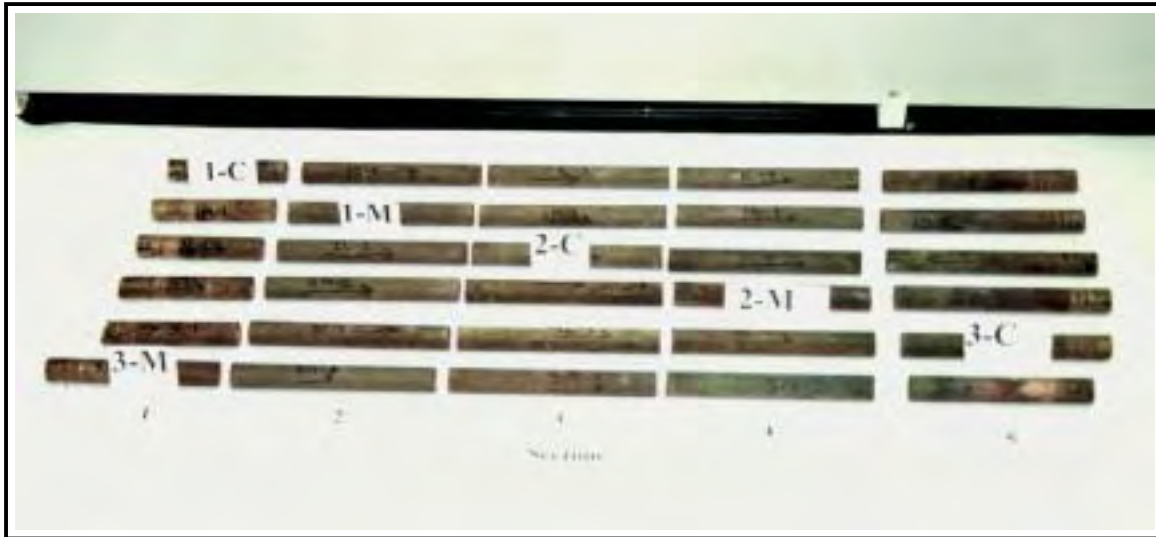

Figure 11. Heat exchanger segments.

The actual heat exchanger tubes were made of copper tube ($\frac{3}{4}$ -in. O.D. $\frac{5}{8}$ -in. I.D.) cut into 30-in. sections. The weight of the tube sections ranged from 380.96 to 382.62 g. The tube was then placed in the heat exchanger, using compression fittings to provide a seal. After the testing was concluded, the ends of the tube were cut and the tube was removed from the heat exchanger. To prevent the loss of loose scale, the ends of the tube were sealed with duct tape. The section of the assembly immediately following, from the end of the tubes through the flow meter, was also collected and sealed. The heat exchanger body was 25 in. long with 1 in. extensions on both ends for compression fittings. Each of the heat exchanger tubes was cut into five sections (Figure 12) for evaluation. The first and last sections included a segment of tube that was protruding from the heat exchanger. The end sections of tube were 4 to 6.5 in. long. The middle three sections were all exactly 6 in. long.

The original intent was to try to determine if the amount of scale was significantly different in the various portions of the heat exchanger tubes. However, the scale that formed was of the “eggshell” type that is very brittle, and spalls with stress. This made evaluation of the individual sections impractical. However, segmenting the tubes did make the step of mechanical removal much easier. Scale that came loose from the tube before it was cut into sections was collected.

Each tube section was tapped with a hammer and scraped to remove loose scale, which was collected individually. Loose scale from the section after the heat exchanger was also collected. The restricted opening to the flow meter trapped some of the scale, when it broke off the copper tube. The collected scale was air dried and weighed. Only scale from the middle three sections of tube was used

for X-Ray Diffraction analysis, since it was judged deposits in those sections would be the most consistent in thickness and type. Scale from the middle three sections of tube for each heat exchanger was placed in a tungsten carbide container and mixed in a SPEX 8000 powder mill for 20 minutes. The resulting powder was mounted using methanol in a cavity slide. The diffraction pattern was obtained using a Rigaku Rotaflex RU 200B X-ray Diffractometer with a rotating copper anode run at 35kV and 50mA. The resulting diffraction pattern was identified using Jade 3.1 software and the International Center for Diffraction Data database on CD-ROM.

Not all the scale could be removed mechanically, therefore chemical methods were employed. Hydrochloric (HCl) and nitric (HNO₃) acid were used to remove the remaining scale. A section of tube was placed in a 4000 mL beaker containing about 500 mL deionized water and 20 mL concentrated HNO₃ and 50 mL concentrated HCl. Gas was released as the scale dissolved. Depending on how much scale was present, the reaction lasted from a few seconds to several minutes. When the reaction stopped, the tube was removed, rinsed with deionized water into the beaker, and placed on a paper towel. This procedure was employed with the remaining four sections of tube from that heat exchanger. An additional aliquot of both acids were added to the beaker.

The process was repeated to ensure that all scale was removed. The contents of the beaker was diluted to 2L using a Class A volumetric flask, resulting in a final acid concentration of approximately 5 percent HCl and 2 percent HNO₃. This was then diluted 1:10 for ICP analysis. This entire procedure was repeated with the remaining five groups of tube sections. The concentration of calcium and magnesium found by ICP was converted to calcium carbonate. The concentration (in mg/L) was multiplied by two since the final volume of the solution was 2L, and the total weight of scale removed was recorded.

While the primary purpose of this study was to determine the effectiveness of the three devices in controlling calcium hardness scale formation, the decision was made to monitor the corrosion rate as well to determine if there was a measurable effect by the devices. Since copper tube was used for the heat exchangers, only copper coupons were employed in this study. The copper coupon analysis was processed using ASTM D2688-90, Method B. The authors provided each of the device manufacturers with a copy of the test plan before the study started, and implemented as many of their suggested changes as possible. The test plan is found in Appendix B of this report. This study was not designed to test the validity of the theory of operation for any of the devices, merely to test them in as close to a "real world" environment as possible while still providing some control of the operating environment.

4 Test Results

The corrosion coupon results (detailed in Table D10) showed no significant impact on the corrosion rate. The control and device coupons all had approximately 0.03 g of metal loss. Figures 8 and 9 show the coupons after removal from the test apparatus and after cleaning. There is no indication of either an increase or decrease in the corrosion rates of the coupons in the magnetic and electronic devices versus the control loops. The corrosion rate, calculated as mmpy (millimeters penetration per year) for the coupons was 0.32 to 0.43 in the heat exchangers and 0.45 for the cold potable water.

The water samples that were analyzed (Tables A4-A9) showed very little difference in measurable water quality parameters for either the device or the control versus the cold potable water used as a supply. The manufacturers of magnetic devices do not claim any measurable change in water quality as a result of using their device, but these tests were done to confirm the consistency of the water supply and confirm that no change was taking place.

Flakes of scale were visible in the flow meters (Figure 11) during the course of the test. This material was collected and totaled with the other scale in Table D11. Since this is material that was formed in the heat exchangers, it was considered it in the evaluation of the results. The temperatures of the influent water, and of the water leaving all of the control and device heat exchanger tubes were recorded daily, once each shift, for the duration of the test period. This information is recorded in Table D3. When mineral scale forms on heat exchange surfaces, the efficiency of the unit decreases. The measure of a heat exchangers' efficiency is the amount of temperature change (ΔT [T]) through the unit. When fluid is being heated, this is determined by subtracting the influent temperature from the effluent temperature.

Figures 12 through 14 detail the change in temperature for both the control and the device heat exchange tubes. Since the control tubes were scaling, and performance deteriorated rapidly, the temperature increase of the water flowing through those heat exchange tubes dropped. If the devices were preventing mineral scale from forming, the heat exchange tubes associated with the devices would have higher rate of temperature increase, or ΔT . If the devices did not prevent mineral scale from forming, then the temperature increase for both the device and control would be the same. The Descal-A-Matic device (1M) had 3.8

percent less scale than the control (1C), which is well within the expected experimental error for this type of test. The ΔT , or temperature change (Figure 12), through the two tubes was virtually identical for most of the test period, a further indication that the amount of difference in scale accumulation was insignificant relative to the efficiency of the heat exchange taking place. The Aqua Magnetic device (2M) had 3.3 percent less scale than its control (2C), which was also deemed to be statistically insignificant. The ΔT , or temperature change (Figure 13) for Heat Exchanger 2 also indicates the performance for the device and the control were very similar.

Figure 14 shows that the ΔT , or temperature change, for both the Ener-Tec device and the control were very similar until 25 October 1999. This coincides with the shutdown of the loop for the replacement of a leaking section in the CPVC water side loop. Steam and water were shut off at 7:00 p.m. 23 October 1999. The system was brought back on line after repairs were completed at 11:00 a.m. 25 October 1999. It is suspected that the repair process resulted in a mechanical or thermal impact that caused some spalling of the scale to occur on the Ener-Tec heat exchanger tube surface, which accounts for the difference in ΔT after that point. The last readings were taken before shutdown at 3:00 p.m. 23 October 1999, at which time the temperature for the Ener-Tec and its control were nearly identical (100 °F and 98 °F, respectively).

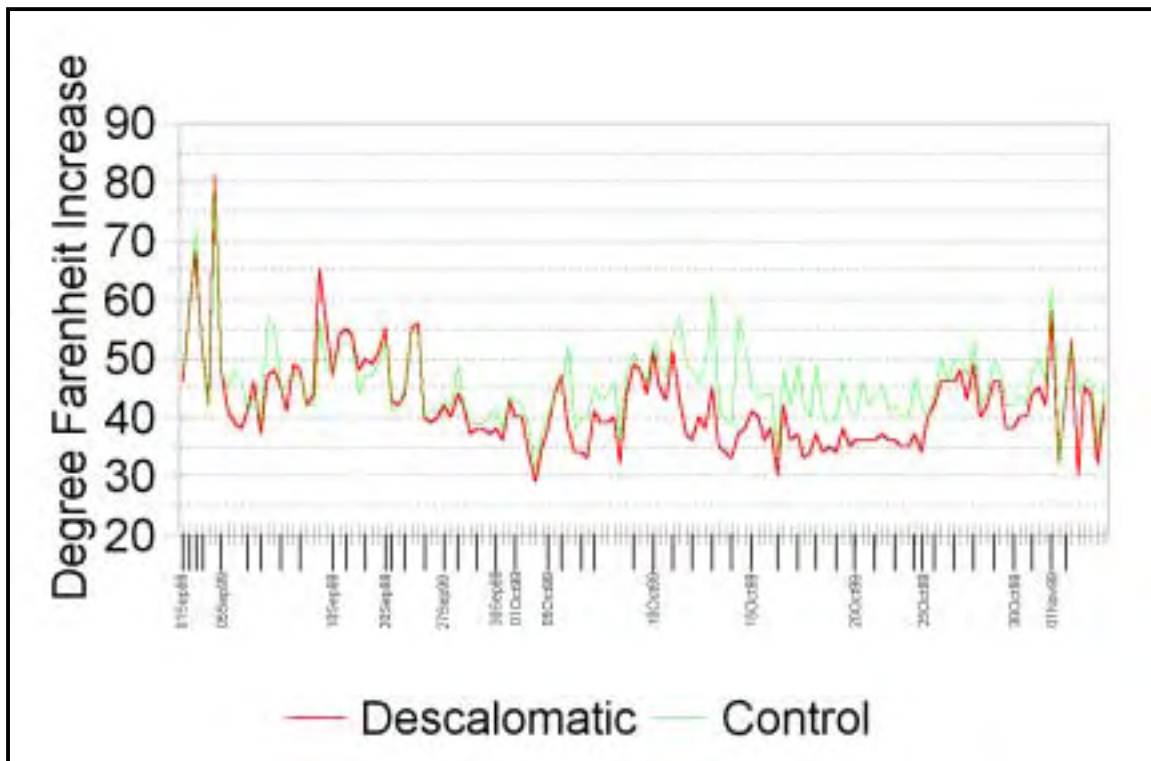

Figure 12. Temperature change heat exchanger #1.

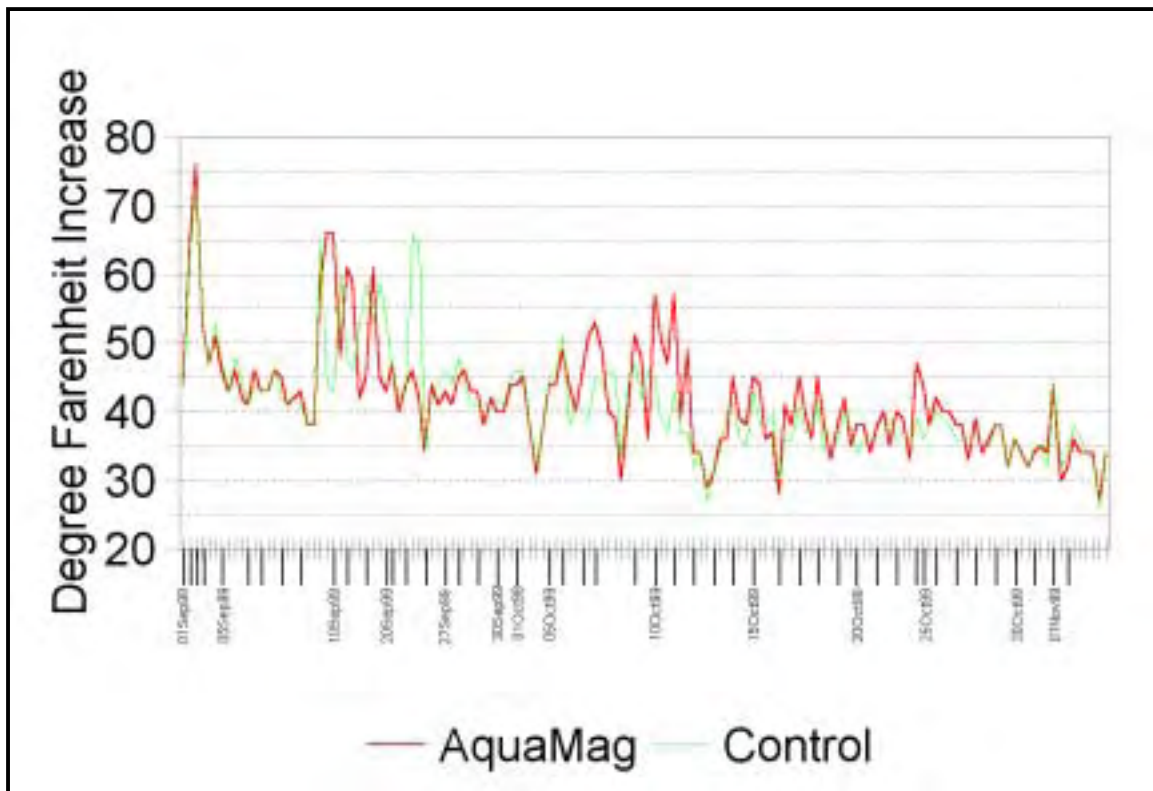

Figure 13. Temperature change heat exchanger #2.

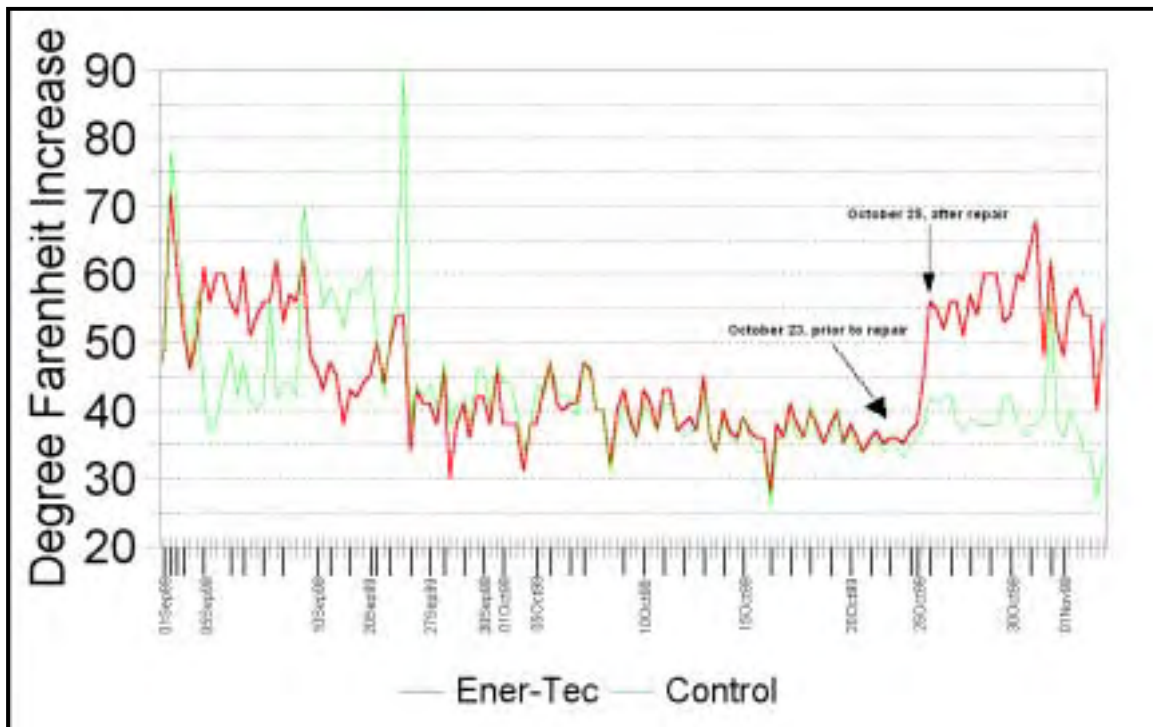

Figure 14. Temperature change, heat exchanger #3.

Once the system was restarted, a difference in T developed due to the spalling of scale on the Ener-Tec tube, which exposed clean copper surfaces. The temperature exiting the heat exchanger with Ener Tec device was still well below the original operating temperature of 140 °F, with the temperature averaging about 115 °F.

The resulting XRD patterns were almost identical. **Figure 15** shows all six of the patterns on the same page to make the comparison of the individual patterns easier. The fact that they are all basically the same material is obvious from this comparison. This is further reinforced in **Figure 16** where all six patterns were overlaid on the same plot. This clearly shows the relative peak height and spacing is nearly identical for all six samples. Individual plots for all six samples are shown in **Figures 17 to 22**. Evaluation of the samples indicated that all six samples were primarily a form of calcite. The XRD scans for the six samples have the reference peaks for this compound added (vertical lines) for easy reference. The peak spacing and intensity indicate an excellent match. Many magnetic device manufacturers assert that their products change the preferential form of calcium carbonate from calcite to aragonite.

This was clearly not the case in this study. **Figure 23** further illustrates this by showing one of the samples with the reference peaks for aragonite. (A single sample suffices here since, as shown in **Figure 16**, all six samples showed virtually identical XRD patterns.) The peak spacing is radically different from any of the samples, and the compound is clearly not aragonite. The particular type of calcite found was a magnesium calcite. **Figure 24** contains the ICDD reference data for this compound, PDF#43-0697. The reference sample for PDF#43-0697 had a ratio of 86.1 CaO to 13.6 MgO. This is very similar to the data obtained from the ICP analysis of the material removed from the heat exchanger tubes. This data is listed in Table D12.

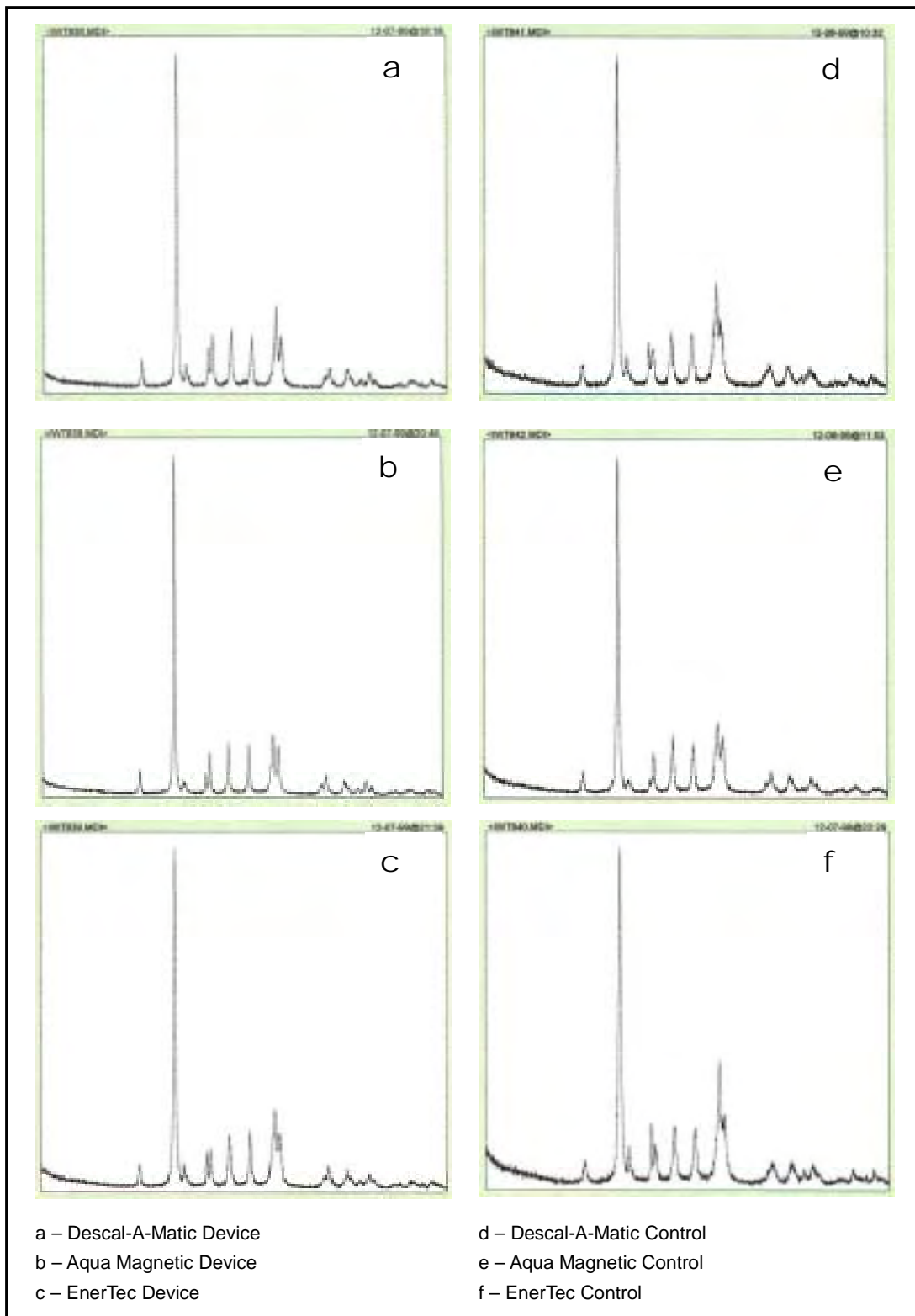

Figure 15. XRD pattern comparison.

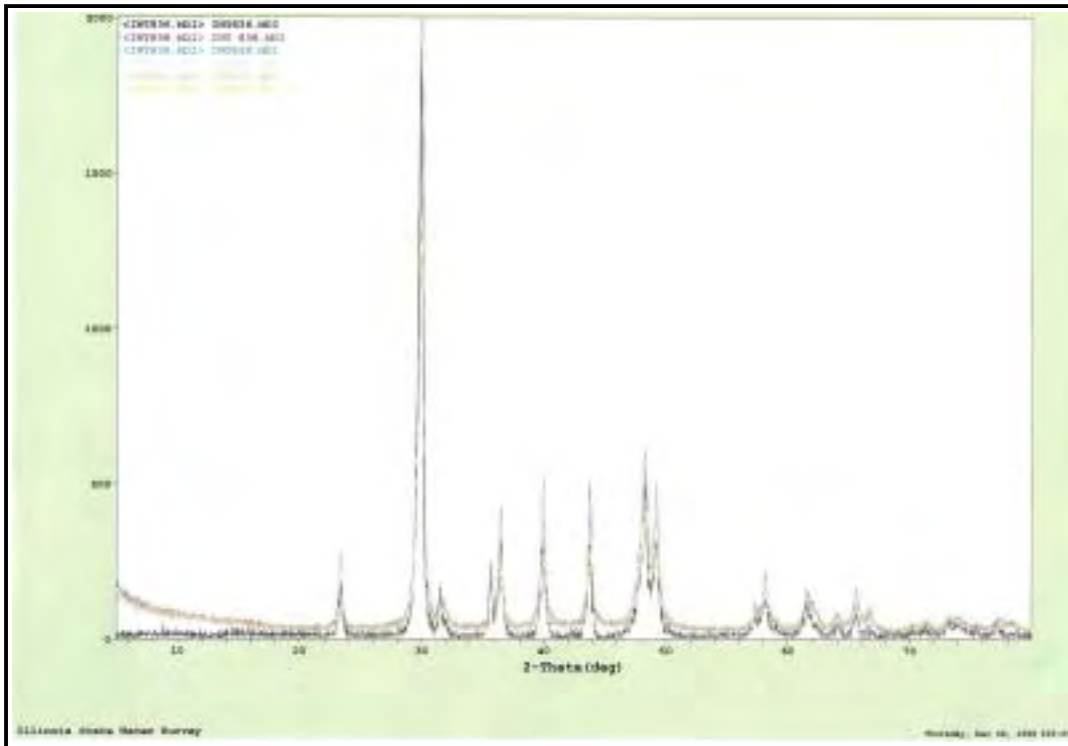

Figure 16. XRD pattern overlay.

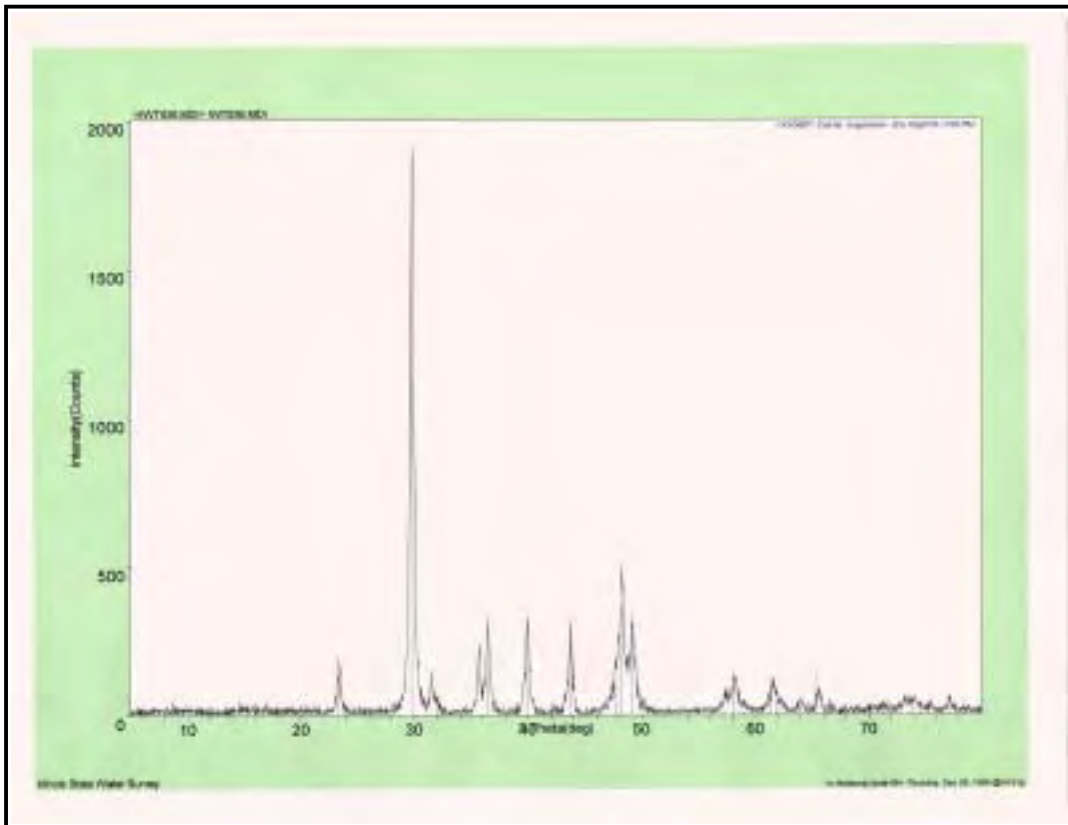

Figure 17. Descal-A-Matic device XRD patterns.

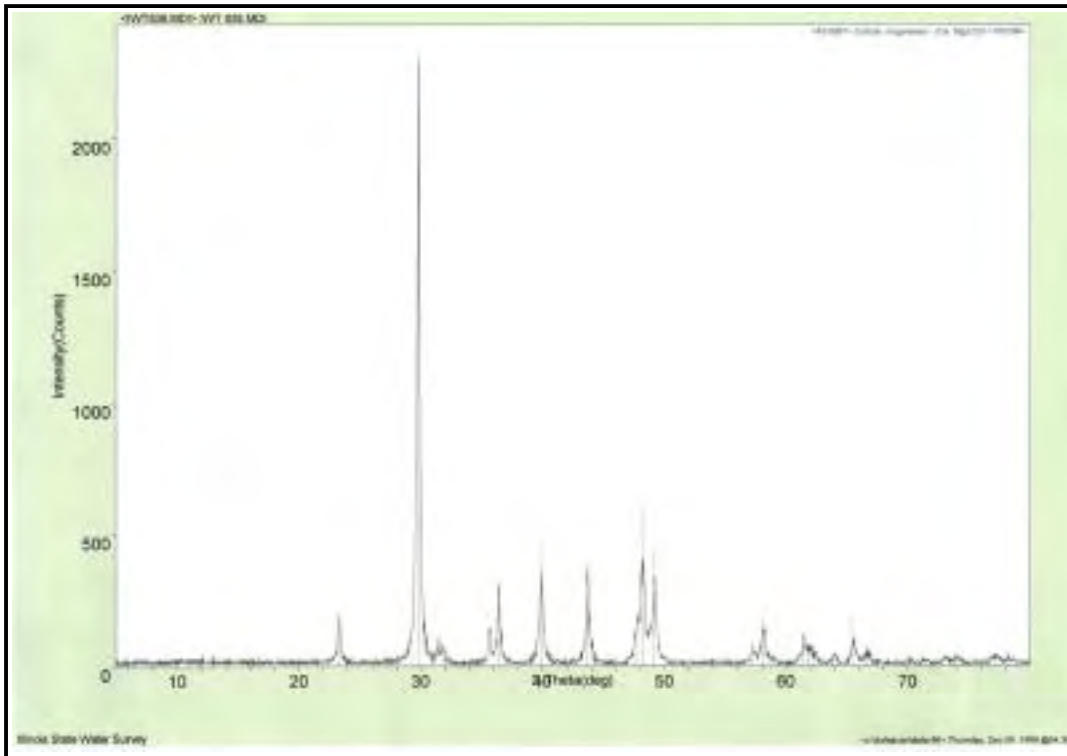

Figure 18. Aqua Magnetic device XRD pattern.

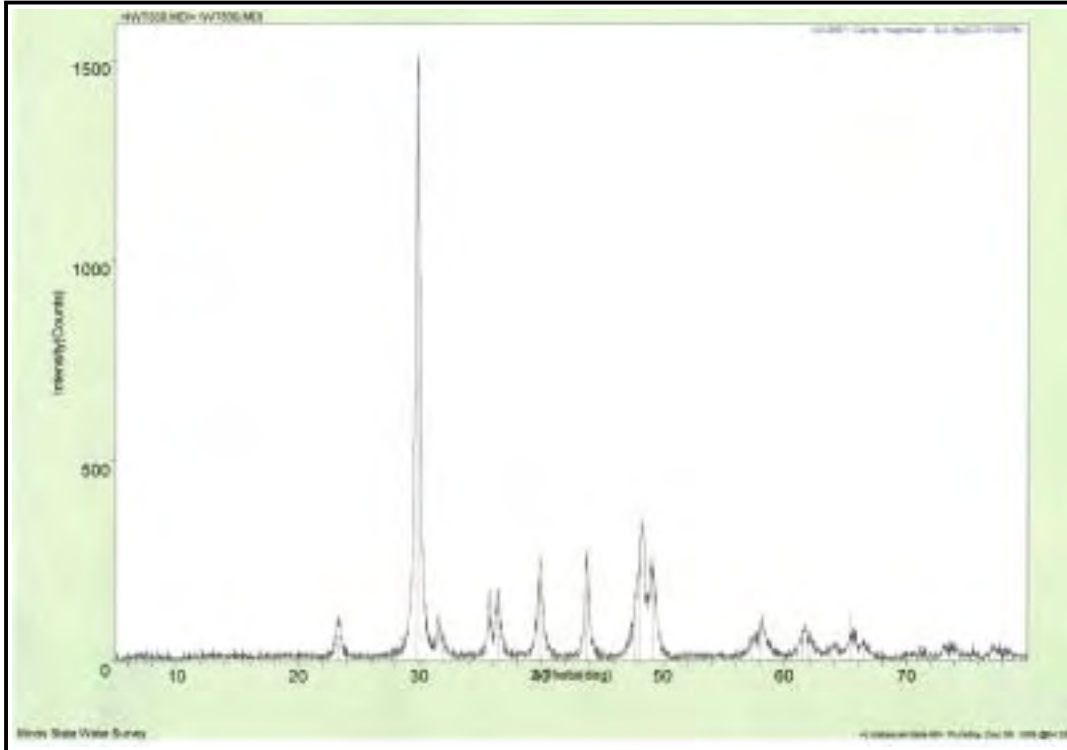

Figure 19. EnerTec device XRD pattern.

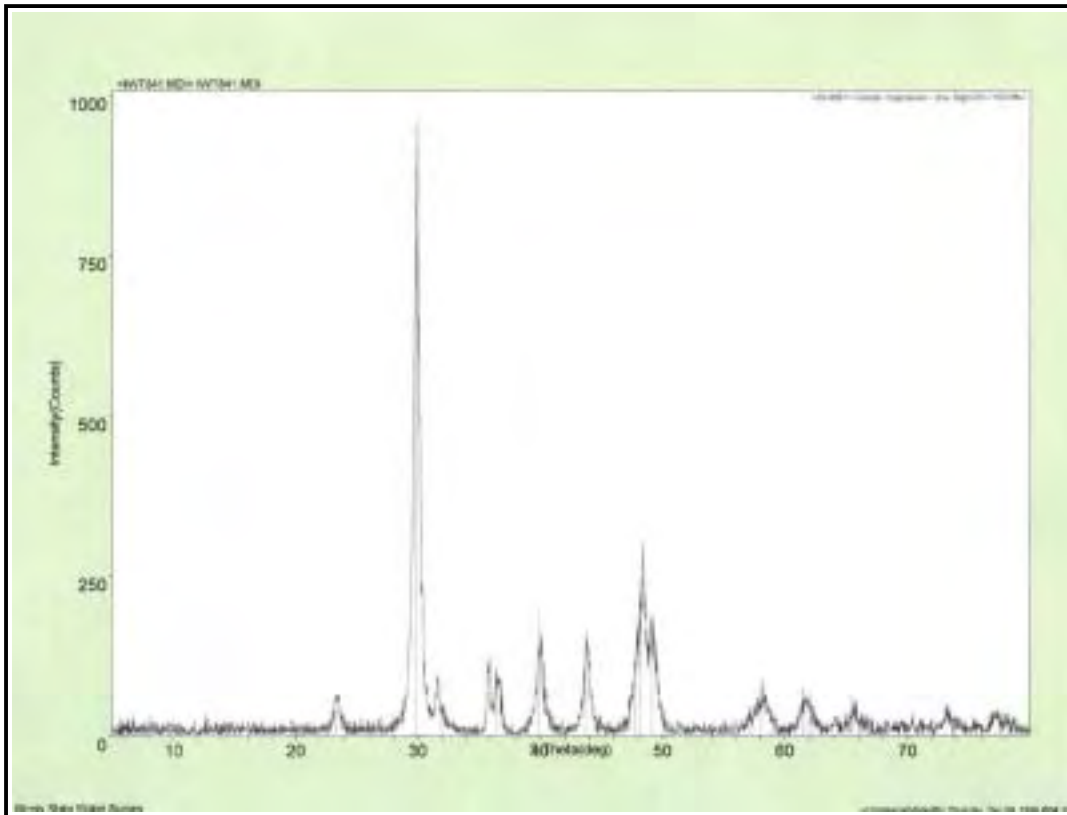

Figure 20. Descal-A-Matic device control XRD pattern.

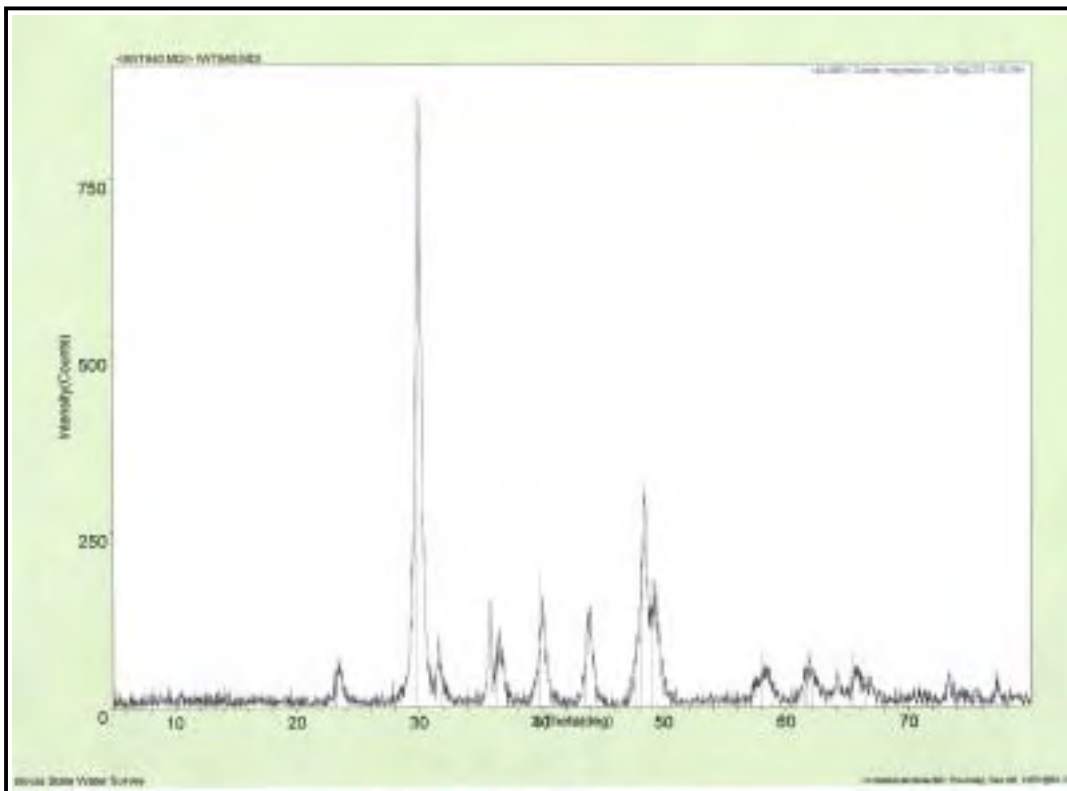

Figure 21. Aqua Magnetic device control XRD pattern.

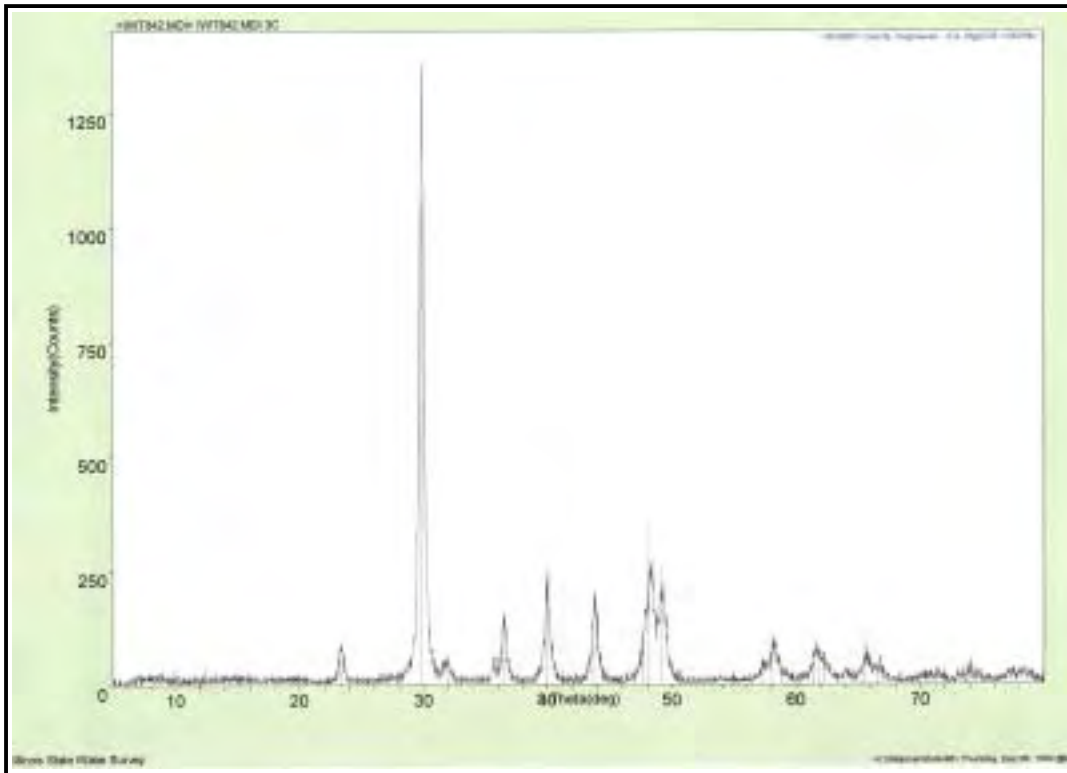

Figure 22. EnerTec device control XRD pattern.

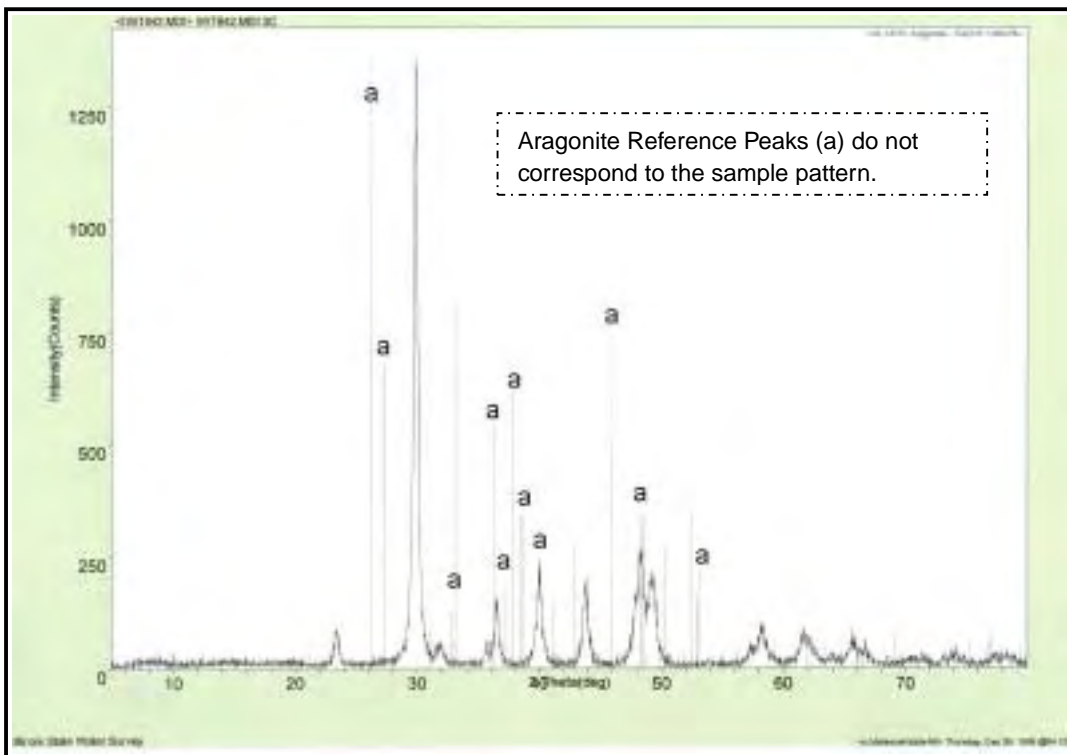

Figure 23. Aragonite reference peaks.



Figure 24. Calcite (magnesian) PDF card #43-0697.

5 Conclusions

The results of this study show that the amount of mineral scale formed for the control versus device heat exchange tubes was relatively constant, and proved to be an effective insulator of heat transfer across the tube surface. The scale formed was found to be a type of calcite (calcium carbonate), and had the same crystalline structure for each heat exchange tube. There was no discernible effect on the crystalline structure of the scale formed by any of the tested devices.

This study concludes that these results indicate no clear advantage for any of the three devices tested over a control for the inhibition of mineral scale formation or the corrosion of copper. The test protocol was designed to simulate the method of production of hot water used in many larger institutional type settings that employ a shell and tube heat exchanger for the production of hot water. These findings do not support the claims of the manufacturers regarding the ability of their respective devices to prevent mineral scale formation in hot potable water systems.

Bibliography

- Alleman, James E., *Quantitative Assessment of the Effectiveness of Permanent Magnetic Water Conditioning Devices* (Water Quality Association [Research Reports], November 1985).
- Baker, John S., and S.J. Judd, "Magnetic Amelioration of Scale Formation," *Wat. Res.*, vol 30, No. 2 (1996), pp 247-260.
- Busch, Kenneth W., et al., "Laboratory Studies Involving Magnetic Water Treatment Devices," *Proceedings National Association of Corrosion Engineers Annual Conference* (March 1984).
- Busch, Kenneth W., et al., "Magnetic Water Treatment Devices, the Results of a University Study," *Proceedings International Water Conference* (October 1984).
- Busch, Kenneth W., et al., "Studies of a Water Treatment Device That Uses Magnetic Fields," *National Association of Corrosion Engineers*, vol 42, No. 4 (April 1986), pp 211-221.
- Busch, Kenneth W., Marianna A. Busch, "Laboratory Studies on Magnetic Water Treatment and their Relationship to a Possible Mechanism for Scale Reduction," *Desalination*, vol 109, No. 2 (1997), pp 131-148.
- Carpenter, Roland K., *Magnetic Treatment Does Work* (National Association of Corrosion Engineers [NACE] March 1985), pp 252.1-252.8.
- Cho, Young I., Chunfu Fan, Byung-Gap Choi, "Theory of Electronic Anti-Fouling Technology To Control Precipitation Fouling in Heat Exchangers," *Int. Comm. Heat Mass Transfer*, vol 24, No. 6. (1997), pp 757-770.
- Chynoweth, Emma, "Softening Hard Scale," *Process Eng.*, vol 68, No. 5 (1987), p 77.
- Coetzze, P.P., M. Yocoby, and S. Howell, "The Role of Zinc in Magnetic and Other Physical Water Treatment Methods for the Prevention of Scale," *Water SA*, vol 22, No. 4 (1996), pp 319-326.
- Cole, Frank, and Margaret A. Clarke, "Benefits of Permanent Magnets in Factory Evaporation," *Int. Sugar J.*, vol 98, No. 1166 (1996), pp 71-72.
- Cole, Frank, and Margaret A. Clarke, "Effect of Magnetic Field on Evaporator," *Proc. Sugar Process. Res. Conf.* (1993), pp 64-68.
- Colic, Miroslav, Allen Chien, and Dwain Morse, *Synergistic Application of Chemical and Electromagnetic Water Treatment in Corrosion and Scale Prevention* (Croatian Chemical Society, 1998).
- Control Factors in Performance Testing of Nonchemical Water Treatment Devices* (NACE Technical Committee, National Association of Corrosion Engineers [NACE], reaffirmed 1997).

- Cummings, Sean, "Standards for Magnetic Devices Still Seem a Long Way Off," *Water Technology* (April 1998), pp 37-42.
- Dalas, Evengelos, and G.J. Koutsoukos, "The Effect of Magnetic Fields on Calcium Carbonate Scale Formation," *Cryst. Growth*, vol 96, No. 4 (1989), pp 802-806.
- Das, C.R., and H.P. Misra, "Effect of Magnetic Field on Internal Corrosion of Water Pipelines," *J. Inst. Eng.* (1982), vol 63, No. 1, pp 30-31.
- Davies, J.H., "Scale Prevention and Removal by Hydrodynamic Fluid Treatment," *Certif Eng.* (January 1983), vol 56, No. 1, pp 4-10.
- Donaldson, J.D., "Magnetic Treatment of Scale Prevention and Descaling in Water Treatment and Process Systems," *Prod Finish*, vol 39, No. 9 (September 1986), pp 6-8, 10.
- Donaldson, J.D., "Scale Prevention and Descaling," *Tube International* (March 1988), pp 39-49.
- Donaldson, John, and Sue Grimes, "Lifting the Scales From Our Pipes," *New Sci.*, vol 117, No. 1600 (1988), pp 43-46.
- Donaldson, John, and Sue Grimes, "Scale Prevention in Steel Pretreatment by Magnetic Treatment," *Steel Times Int.*, vol 11, No. 5 (1987), pp 44-45.
- Dromgoole, J.C., and M.C. Forbes, "The Fatal Lure of Water Treating Gadgets," *Proceedings National Association of Corrosion Engineers Annual Conference* (November 1979).
- Dromgoole, J.C., and M.C. Forbes, "The Fatal Lure of Water Treating Gadgets," *Proceedings International Water Conference* (November 1979).
- "Electromagnetic Water Conditioners Are Soft Option," *H&V Engineer*, vol 67, No. 724 (1994), pp 12-13.
- Eliassen, Rolf, and Herbert H. Uhlig, "So-Called Electrical and Catalytic Treatment of Water for Boilers," *Journal of the American Water Works Association* (July 1952), vol 44, No. 7, pp 576-582.
- Eliassen, Rolf, and Rolf Skrinde, "Experimental Evaluation of 'Water Conditioner' Performance," *Journal of the American Water Works Association* (September 1957), vol 49, No. 9, pp 1179-1190.
- Ellingsen, Frank, "A Review of Scale Formation and Scale Prevention, with Emphasis on Magnetic Water Treatment," *Water Supply* (1983), vol 1, No. 2-3.
- Emerson, G.D., *Alkalinity - pH Changes with Temperature for Water in Industrial Systems* (Ellis Horwood Limited, 1986).
- Foster D. Snell Inc., *Report to Water Conditioning Research Council on Water Conditioned by an EVIS Unit* (July 1952).
- Giani, Francine, *Consumer Alert: Magnetic Water Treatment Devices Do Not Work*, News Release (Division of Drinking Water, State of Utah, 15 March 1995).

- Grimes, Sue M., "Magnetic Field Effect on Crystals," *Tube International* (March 1988).
- Gruber, C.E., and D.D. Carda, "Performance Analysis of Permanent Magnet Type Water Treatment Devices," *Water Quality Association Research Reports* (July 1981).
- Grutsch, James F., and J. Warren McClintock, "Corrosion and Deposit Control in Alkaline Cooling Water Using Magnetic Water Treatment at Amoco's Largest Refinery," *Proceedings National Association of Corrosion Engineers Annual Conference* (April 1984).
- Hanson, D., D. Bramson, "Effectiveness of Magnetic Water Treatment in Suppressing CaCO₃ Scale Deposition," *Ind. Eng. Chem. Process Des. Dev.* (1985), vol 24, No. 3, pp 588-592.
- Hasson, D., and D. Bramson, "The Performance of a Magnetic Water Conditioner Under Accelerated Scaling Conditions," *Dep. Chem. Eng.* (Technion-Israel Inst. Technol, 1981), pp 217-273.
- Henke, Larry, "Do Magnetic and Electromagnetic Water Conditioners Work?," *Water Conditioning & Purification* (July 1998), pp 70-74.
- Herzog, Ruth E., Qihong Shi, Jay N. Patil, and Joseph L. Katz, "Magnetic Water Treatment: The Effect of Iron on Calcium Carbonate Nucleation and Growth," *Langmuir*, vol 5, No. 3 (1989), pp 861-867.
- Higashitani, Ko, et al., "Effects of a Magnetic Field on the Formation of CaCO₃ Particles," *Journal of Colloid and Interface Science*, vol 156 (1993), pp 90-95.
- Higashitani, Ko, et al., *Measurements of Magnetic Effects on Electrolyte Solutions by Atomic Force Microscope* (Department of Chemical Engineering, Kyoto University, undated).
- Ifill, A.S., J.S. Baker, and S.J. Jud, "Magnetically-Enhanced Chemical Disinfection," *Process Safety and Environmental Protection: Transactions of the Institution of Chemical Engineers*, pt B, vol 74, No. 2 (May 1996).
- Insulating Properties of Scale Russian Paper* (Fluid-Tech International, 1992).
- Katz, J.L., M.R. Reick, R.E. Herzog, and K.I. Parsieglä, "Calcite Growth Inhibition by Iron," *Langmuir*, vol 9, No. 5 (1993), pp 1423-1430.
- Katz, Joseph L., *Mechanistic Study of the Effects of Magnetic Fields on Scale Formation*, Progress Report (The John Hopkins University, August 1988).
- Klassen, V.I., "Magnetic Treatment of Water and Aqueous Systems in Flotation and Thickening of Ores and Coals," *Proceedings VIII International Mineral Processing Congress* (Leningrad, USSR, 1968).
- Klassen, V.I., "Prospects of Using Magnetic Wastewater Treatment," *Vodye Resursy* (State Scientific-Research Institute of Mining and Chemical Raw Materials, USSR, July-August 1981), No. 4, pp 146-151.
- Krenkel, Peter A., "Environmental Engineering 1991," *Proceedings National Association of Corrosion Engineers Annual Conference, Proceedings of the 1991 Specialty Conference* (1991).

- Kronenberg, Klaus J., "Experimental Evidence for Effects of Magnetic Fields on Water," *Institute of Electric and Electronic Engineers Transactions on Magnetics*, vol 1, No. 5 (September 1985), pp 2059-2061.
- Kronenberg, Klaus J., "Magnetic Water Treatment De-Mystified," *Magnets*, vol 2 (1987), p 6.
- Kronenberg, Klaus, "Experimental Evidence for Effects of Magnetic Fields on Moving Water," *IEEE Transactions on Magnetics*, vol 1, No 5. (September 1985), pp 2059-2061.
- Lane, Russell W., *Consulting Services Related to the Theory and Technology of Magnetic Water Treatment*, Contract Report for U.S. Army Construction Engineering Research Laboratory (1981).
- Lane, Russell W., *Control of Scale and Corrosion in Building Water Systems* (McGraw-Hill Inc., 1993), pp 181-182.
- Lawrence, Debbie J., *Evaluation of Commercial Magnetic Descalers*, Technical Report (TR M-342/ADA143020 (U.S. Army Construction Engineering Research Laboratory [CERL] May 1984).
- Legrand, L., and P. Leroy, *Prevention of Corrosion and Scaling in Water Supply Systems* (Ellis Horwood Series in Waste and Waste Water Management, 1990).
- Li, Dexin, et al., "Studies of Some Properties of Magnetically Treated Water," *Proc. Int. Symp. Phys. Magn. Mater.*, vol 2 (1992), pp 809-812.
- Limpert, G.J.C., and J.L. Raber, "Non-Chemical Scale Control Devices," *AWT Analyst* (July 1992), pp 3-11.
- Limpert, G.J.C., and J.L. Raber, "Tests of Non-Chemical Scale Control Devices in a Once-Through System," *Proceedings National Association of Corrosion Engineers Annual Conference* (March 1985).
- Lipus, L., J. Krope, L. Garbai, and J. Hung, "Magnetic Water Treatment for Scale Prevention," *Ind. Chem*, vol 22, No. 4 (1994), pp 239-242.
- Lipus, L., J. Krope, L. Garbai, and J. Hung, "Magnetic Water Treatment for Scale Prevention," *Ind. Chem*, vol 26, No. 2 (1998), pp 109-112.
- Magnetic Water Treatment Russian Paper* (Fluid-Tech International, 1992).
- "Magnets That Don't Do Much To Soften Water," *Consumer Reports* (February 1996), p 8.
- Mars, G., and Norbert R. Greene, *Corrosion Engineering Fontana* (McGraw-Hill, Inc., 1967), pp 197-198.
- Martynova, O.I., "Efficiency of Some Physical Scale Prevention Methods in Thermal Desalination Plants," *Proc. Int. Symp. Fresh Water Sea* (1980), vol 7, No. 1, pp 399-406.
- Meckler, Milton, Heating, Piping & Air Conditioning, *Electrostatic Descaler Testing: An Evaluation* (August 1974), pp 37-40.

- Milosevic-Kvajic, George and Mirjana, "Magnetic Field Conditioning of Industrial Waters Kvajic," *Proceedings of the International Water Conference* (November 1979).
- NACE Technical Committee, "Predictably Effective Equipment and In Situ Processes Applied to Water Systems," *Proceedings National Association of Corrosion Engineers Annual Conference* (June 1998).
- Non-Chemical Technologies for Scale and Hardness Control*, DOE/EE-0162 (U.S. Department of Energy, January 1998).
- Paiaro, Sastone, and Luciano Pandolfo, "Magnetic Treatment of Water and Scaling," *Ann. Chim*, vol 84, No. 5-6 (1994), pp 271-274.
- Parson, S.A., W. Bao-Lung, S.J. Judd, and K. Udol, *Magnetically Augmented Water Treatment* (School of Water Sciences, Cranfield University, 1997).
- Parson, S.A., W. Bao-Lung, S.J. Judd, T. Stephenson, "Magnetic Treatment of Calcium Carbonate Scale-Effect of pH Control," *Wat. Res.*, vol 31, No. 2 (1997), pp 339-342.
- Prevention & Control of Water-Caused Problems in Building Potable Water Systems*, TPC Publication 7, 2d ed. (NACE International, 1995).
- Puckorius, P., "Mechanical Devices for Water Treatment: Just How Effective are They?," *Power* (January 1981), pp 60-62.
- Raisen, Elliott, "The Control of Scale and Corrosion in Water Systems Using Magnetic Fields," *Proceedings National Association of Corrosion Engineers Annual Conference* (April 1984).
- Reimers, R.S., A.C. Anderson, and L.E. White, "Reviewing the Usage of Applied-Fields in Industrial Water Treatment-What Works? What Does Not Work?," *Proc. Int. Water Conf.* (Eng. Soc. West. PA. 44th, 1983), pp 280-291.
- Reimers, R.S., P.S. deKernion, F.C. Robedeau, and D.B. Leftwich, "A Viable Approach to Water and Wastewater Treatment," *Water Technology* (May-June 1980), pp 44-65.
- Robert, et. al., "Using Magnetic Fields To Prevent Scale Benson," *Chemtech*, vol. 27, No. 4 (1997), pp 34-38.
- Rosa, Frank, *Water Treatment Specification Manual* (McGraw-Hill, Inc., 1985), pp 190-191.
- Silman, Harold, "Magnetic and Electrostatic Methods of Water Treatment," *Met. Finish*, vol 88, No. 8 (1990), pp 19-20.
- Soloman B. Williams, *Non-Chemical Water Treatment Technology in Energy Savings Performance Contracting* (Tyndal AFB FL, undated).
- Soviet Work in the Area of Non-Chemical Fluid Treatment Russian Paper* (Fluid-Tech International, 1992).
- Spear, Mike, "Growing Attraction of Magnetic Treatment," *Process Eng*, vol 73, No. 5 (May 1992), pp 143.

- Srebrenik, S., "Magnetic Treatment of Water—A Theoretical Quantum Model," *Magnetic and Electrical Separation*, vol 5, No. 2 (1993), pp 71-91.
- Standard Methods*, 17th ed. (joint publication of the American Public Health Association, American Water Works Association, Water Pollution Control Federation, and American Public Health Association, 1989), pp 3-54.
- Takasaki, S., K. Parsiegla, J.L. Katz, "Calcite Growth and the Inhibiting Effect of Iron (III)," *Journal of Crystal Growth*, vol 143 (1994), pp 261-268.
- Uhlig, Herbert H., "Corrosion Control by Magic - It's Wonderful," *Corrosion* (November 1952), vol 8, pp 361-363.
- Van Den Hoven, Th., et al., *Point-of-Use Treatment: Experience with Physical Water Conditioners in the Netherlands* (Kiwa NV, Nieuwegein, 1994).
- Wang, Chuha, R. Benson, and Dean F. Martin, "Removal of Iron From Sodium Fluorosilicate Scale by Magnetic Treatment," *Fla. Sci*, vol 61, No. 2 (1998), pp 88-95.
- Wang, Y., A.J. Babchin, and L.T. Chernyl, "Rapid Onset on Calcium Carbonate Crystallization Under the Influence of a Magnetic Field," *Water Res.*, vol 31, No. 2 (1997), pp 346-350.
- Water Hardness Russian Paper* (Fluid-Tech International, 1992).
- Water Quality Association Position Paper on Catalytic, Electromagnetic, and Magnetic Devices Claimed To Treat Drinking Water*, rev. July 1994.
- "Water Treatment—The Soft Option," *H&V Engineer*, vol 67, No. 722 (1994), pp 6-8.
- Webster, H.A., *Basics of Magnetism* (Correng Publications Service Inc., September 1998), pp 1-12.
- Welder, B.Q., and Everett P. Partridge, "Practical Performance of Water-Conditioning Gadgets," *Industrial and Engineering Chemistry* (May 1954), vol 46, pp 954-960.
- Wescott, Ralph M., "Nonchemical Water Treating Devices," *Materials Performance* (November 1980), pp 40-42.
- "Who Knows the Secret of the Black Magic Tube?," *Finishing*, vol 14, No. 4 (April 1990), pp 27-28.
- Wilkes, J. Fred, and Ray Baum, "Water Conditioning Devices—An Update," *Proceedings of the International Water Conference* (November 1979).

Appendix A: Field Test Work Plan Transmittal Letters

**DEPARTMENT OF THE ARMY**

CONSTRUCTION ENGINEERING RESEARCH LABORATORIES, CORPS OF ENGINEERS
P.O. BOX 9005
CHAMPAIGN, ILLINOIS 61828-9005

REPLY TO
ATTENTION OF

July 22, 1999

Materials & Structures Branch

Mr. Roland Carpenter
Aqua-Magnetics
915-C Harbor Lake Drive
Safety Harbor, Florida 34695

Dear Mr. Carpenter:

The purpose of this letter is to provide you a copy of the U.S. Army Construction Engineering Research Laboratory (CERL) field test plan for the evaluation of Magnetic Descalers for your review prior to the start of the field test.

The objective of this study is to conduct an unbiased evaluation of commercial Magnetic and Electrostatic Water Treatment Devices. The test apparatus will be constructed on-site at CERL in Champaign, Illinois and installed at the Rock Island Arsenal Water Treatment Plant in Rock Island, Illinois. The field test plan is designed to simulate a typical domestic hot water system. The potable water will be magnetically treated prior to entry into a small steam fed heat exchanger. The water temperature and flow rate will be monitored and controlled throughout the test. The testing will be completed over a three to four week period. At the conclusion of the test a complete evaluation of the water quality, indices, and any mineral scale formed on the test coupons will be performed.

The field test plan is enclosed for your review and evaluation. We look forward to hearing from you. If you have any questions, please call Vince Hock 1-800-USACERL Ext. 6753 or Brian Gard Ext. 7635. Thank you for your time.

Sincerely,

Vincent Hock

Copy Furnished:

Nelson Labbe

REPLY TO
ATTENTION OF

DEPARTMENT OF THE ARMY

CONSTRUCTION ENGINEERING RESEARCH LABORATORIES, CORPS OF ENGINEERS
P.O. BOX 9005
CHAMPAIGN, ILLINOIS 61826-9005

July 22, 1999

Materials & Structures Branch

Mr. Larry Shroyer
Enertech
PO Box 85
Union City, Michigan 49094

Dear Mr. Shroyer:

The purpose of this letter is to provide you a copy of the U.S. Army Construction Engineering Research Laboratory (CERL) field test plan for the evaluation of Magnetic Descalers for your review prior to the start of the field test.

The objective of this study is to conduct an unbiased evaluation of commercial Magnetic and Electrostatic Water Treatment Devices. The test apparatus will be constructed on-site at CERL in Champaign, Illinois and installed at the Rock Island Arsenal Water Treatment Plant in Rock Island, Illinois. The field test plan is designed to simulate a typical domestic hot water system. The potable water will be magnetically treated prior to entry into a small steam fed heat exchanger. The water temperature and flow rate will be monitored and controlled throughout the test. The testing will be completed over a three to four week period. At the conclusion of the test a complete evaluation of the water quality, indices, and any mineral scale formed on the test coupons will be performed.

The field test plan is enclosed for your review and evaluation. We look forward to hearing from you. If you have any questions, please call 1-800-USACERL Vince Hock Ext. 6753 or Brian Gard Ext. 7635. Thank you for your time.

Sincerely,

A handwritten signature in cursive script that reads "Vincent F. Hock".

Vincent Hock

Copy Furnished:

Nelson Labbe



DEPARTMENT OF THE ARMY
CONSTRUCTION ENGINEERING RESEARCH LABORATORIES, CORPS OF ENGINEERS
P.O. BOX 9005
CHAMPAIGN, ILLINOIS 61828-9005

REPLY TO
ATTENTION OF

July 22, 1999

Materials & Structures Branch

Mr. Ernie Florestano
Mr. Norman Powers
Descal-A-Matic
4855 Brookside Court
Norfolk, Virginia 23502

Dear Mr. Florestano and Mr. Powers:

The purpose of this letter is to provide you a copy of the U.S. Army Construction Engineering Research Laboratory (CERL) field test plan for the evaluation of Magnetic Descalers for your review prior to the start of the field test.

The objective of this study is to conduct an unbiased evaluation of commercial Magnetic and Electrostatic Water Treatment Devices. The test apparatus will be constructed on-site at CERL in Champaign, Illinois and installed at the Rock Island Arsenal Water Treatment Plant in Rock Island, Illinois. The field test plan is designed to simulate a typical domestic hot water system. The potable water will be magnetically treated prior to entry into a small steam fed heat exchanger. The water temperature and flow rate will be monitored and controlled throughout the test. The testing will be completed over a three to four week period. At the conclusion of the test a complete evaluation of the water quality, indices, and any mineral scale formed on the test coupons will be performed.

The field test plan is enclosed for your review and evaluation. We look forward to hearing from you. If you have any questions, please call 1-800-USACERL Vince Hock Ext. 6753 or Brian Gard Ext. 7635. Thank you for your time.

Sincerely,

Handwritten signature of Vincent A. Hock in cursive script.
Vincent Hock

Copy Furnished:

Nelson Labbe

Appendix B: Field Test Work Plan

USA CERL Technical Report
June 1999
Material and Structures Branch (CF-M)

FIELD TEST OF MAGNETIC DESCALERS

WORK PLAN

Vincent F. Hock
Brian T. Gard
U.S. Army Construction Engineering Research Laboratory

Kent W. Smothers
Charles D. Curtiss
Analytical Chemistry and Technology Unit
Illinois State Water Survey
2204 Griffith Drive
Champaign, Illinois 61820

ABSTRACT

Mineral scale formation in water distribution piping impedes flow, resulting in pressure and volume reduction and increasing operational costs. Chemical cleaning is both costly and time consuming, and there are health concerns when chemically cleaning potable water systems. Alternatives to chemicals or equipment such as softeners, that are used to prevent scale formation, have been developed. These alternatives purport to use electric or magnetic fields to change chemical and physical conditions in the water in such a way as to prevent mineral scale buildup.

The objective of this work is to conduct a field test of magnetic descaler performance.

FOREWORD

This technical report was prepared for the United States Army Corps of Engineers Construction Engineering Research Laboratory (USA CERL) under contract DACA88-99-M-0100, Field Test of Magnetic Descaler Technology by Kent W. Smothers and Charles D. Curtiss of the Analytical Chemistry and Technology Unit, Illinois State Water Survey, Illinois Department of Natural Resources. The USA CERL technical monitor was Vincent Hock.

The authors would like to express their appreciation to Loretta Skowron and Jeremy Overman of the Illinois State Water Survey, who conducted the laboratory analyses for the project.

CONTENTS

SF298 1
FOREWORD 2
LIST OF TABLES 4
1 INTRODUCTION 5
 Background 5
 Objective 5
2 LITERATURE SEARCH 5
3 TEST PROCEDURE 7
APPENDIX A: Tables 9
APPENDIX B: Literature Search Bibliography 13
APPENDIX C: Schematic of Test Apparatus 19

TABLES

Number	Page
A1 Magnetic/Electrolytic/Electronic Devices	9
A2 Water Chemistry Analyses	11
A3 Daily Operation Log Sheet	12

FIELD TEST OF MAGNETIC DESCALERS

WORK PLAN and LITERATURE SEARCH

1 INTRODUCTION

Background

Mineral scale formation in water distribution piping impedes flow, resulting in pressure and volume reduction and increasing operational costs. Chemical cleaning is both costly and time consuming, and there are health concerns when chemically cleaning potable water systems. Alternatives to chemicals or equipment such as softeners, that are used to prevent scale formation, have been developed. These alternatives purport to use electric or magnetic fields to change chemical and physical conditions in the water in such a way as to perform one or all of the following functions: prevent mineral scale buildup, remove existing scale, inhibit corrosion, and control algae and bacteria.

Magnetic/electrostatic devices have generated conflicting opinions on their effectiveness. In 1984, USA CERL was commissioned to evaluate magnetic devices. Technical Report M-342, published that year, concluded that the magnetic devices tested were unable to control corrosion and/or mineral scale formation in both heating and cooling applications. Again, in 1996, USA CERL evaluated literature supplied by one magnetic treatment device, and found no compelling technical evidence to support the companies' claims.

However, some literature sources have reported some positive effects by magnetic fields in laboratory experiments. In light of this activity, the Department of Energy Federal Energy Management Program has issued a publication that supports the need for unbiased evaluation of current commercial magnetic and electrostatic water treatment devices. A similar study was conducted at Tyndal AFB in Florida, but the results were insufficient to evaluate the performance of such devices.

Objective

The objective of this work is to conduct a field test of magnetic descaler performance. The results will be used to evaluate whether or not the specific devices tested were effective in preventing mineral scale formation in this study.

2 LITERATURE SEARCH

Prior to initiation of the test of the magnetic/electrostatic water treatment devices, a complete literature search needs was done to identify key test parameters and operational constraints. The results of the literature search¹⁻⁹² are listed in Appendix B of this document. The authors have identified a total of more than 90 references as of this time. The literature search will continue during the test procedure as well, in the hopes of identifying additional sources of information.

There are many types of nonchemical water treatment devices which are widely accepted within the engineering community for being predictably effective⁸⁷ in a given application and set of operating conditions. This would include technologies such as filters, separators, deaerators, reverse osmosis, cathodic protection and electro dialysis among others. These devices all perform in a predictable and reliable fashion under a given set of circumstances. The principles on which they operate are well understood and can be easily explained, and the performance under a given set of circumstances can be accurately gauged before they are selected for a specific application. However, this cannot be said about catalytic, electrostatic, electrolytic, electronic and magnetic water treatment devices. There is a great deal of controversy concerning their effectiveness, and the explanation for how they actually work changes with time and between different manufacturers of the same type of device.

Respected and recognized leaders in both the scientific and consulting engineering community have long expressed a great deal of skepticism regarding the claims of devices such as those listed in Table A1. Herbert H. Uhlig, longtime chairman of the highly respected Corrosion Laboratory in the Department of Metallurgy at the Massachusetts Institute of Technology, was one of the first members of the scientific community to address the issue. He wrote several editorial style papers^{1,2} in the 1950's which dismissed these devices for being based on pseudoscientific principles. This trend continues to this day, and has more recently been echoed by respected consulting engineers^{9,10,17} who have encountered field installations of these devices. Authors of books on corrosion engineering⁶ and corrosion control^{32,61} consistently admonish consumers to regard any of these products with extreme caution.

There have been numerous papers presented based on actual field trials and laboratory tests of various devices which propose to operate based on magnetic, electrolytic, electrostatic, catalytic, and other principles which find little or no positive effects for these units under controlled conditions. The first device which proposed to operate on catalytic principles was the EVIS unit, which was marketed in the 1950's, and generated a great deal of publicity and ultimately the withdrawal of the device from the market. The notoriety of this case generated interest and considerable research^{3,5} which largely discredited the manufacturers performance claims. Since this time, numerous studies^{4,8,9,27} conducted by consulting engineering firms and government research institutions involving field trials of electrostatic and magnetic devices have disputed the manufacturers performance claims. There have also been several laboratory studies^{27,31,33} which report little or no positive impacts on the control of scale and corrosion by magnetic devices. Katz has done a number of studies^{44,45,59,65} to determine if magnetic fields may

effect iron particles in solution that could act as nucleation sites for calcite formation. However, he has not found any positive effect of magnet water treatment devices on this process. Coetzze has theorized in one study⁷³ that it was actually the dissolution of zinc from a device that produced the positive effect attributed to the magnetic field. There are certain states⁷⁰ and Canadian provinces which have either banned the sale of some devices entirely or issued consumer alerts stating the devices do not work.

However, there are many people who remain convinced that these devices do work. During the last several years however, there have been numerous articles relating laboratory and field studies supporting the efficacy of these devices for mineral scale control, and most of these propose some theory which explains the performance of the unit in question. While several field studies^{7,11,14,25,29} have been reported in the literature, probably the one most cited is the paper²⁵ by Grutsch and McClintock of Amoco Oil Company. However, it should be noted that the use of magnetic water treatment devices was stopped soon after that paper was presented, and the company has effectively distanced themselves from the results indicated in the paper. There have been several studies^{15,26,28,61,76,78} published by university professors or other researchers, which have supported the claims of magnetic or electronic units.

There obviously remains a great deal of disagreement over the effectiveness of magnetic, electrostatic, electrolytic, and electronic water treatment devices. This study can not hope to solve that debate, but it can determine the effectiveness of specific devices in controlling mineral scale formation under operating conditions typical of hot distribution systems in institutional systems.

3 TEST PROCEDURE

Two magnetic and one electronic device will be tested against a control using Rock Island Arsenal Water Treatment Plant (WTP) supply. The magnetically treated potable water will be heated to approximately 160 degrees Fahrenheit. The heat will be supplied by a small steam heat exchanger using available base steam supply in the water plant. Scale will be measured using test coupons that will be placed at the beginning of the loop, before each of the three descaling devices, and after the heating to 160 degrees Fahrenheit. Each heat exchanger will contain a test loop and a control loop. The test heat exchangers are easily disassembled for evaluation upon completion of the study. Tests will be conducted for three to four weeks, or until such time as scale formation results in inadequate flow through the test unit.

The test apparatus will be constructed on-site at CERL facilities in Champaign, and transported to the Rock Island Arsenal WTP for final installation and balancing prior to the test. For ease of transport and installation, the test apparatus will be constructed on a single piece of plywood. Potable water lines will be ¾" CPVC pipe and fittings, and steam/condensate lines will be mild steel. The steam lines and valves will be ¾", and the steam trap and condensate line will be ½". Globe valves will be used for improved accuracy in modulating steam flow. There

will be a temperature gauge in the incoming potable water and exiting each of the three heat exchangers. A pressure gauge will also be installed in the steam supply line. The condensate and hot water effluent will be routed to waste for the duration of the study. There is a trough directly behind the continuous water quality monitoring test station, where the test apparatus will be installed, that is already used for this purpose.

During the course of the study, weekly water samples will be collected of the potable water before it enters the test apparatus, and after it leaves each of the four heat exchangers. Samples will undergo a complete analysis for the constituents listed in Table A2. Calculations will be made using several water quality predictive indices such as LSI, Ryznar, etc. at ambient and test temperature and pH levels. Should time permit, the test may be repeated at a different effluent temperature and/or flow rate.

Each individual heat exchanger will be controlled to maintain the same potable water flow rate (~3gpm) and temperature (160°F) throughout the test procedure. This information will be recorded upon a daily log sheet (Table A3) supplied to the water plant operators that will be monitoring the test apparatus. Upon completion of the test, visual inspection will be made of each heat exchanger and test coupon. Slides will be taken to detail the results. Any mineral scale that forms will be removed, weighed and analyzed. Analysis will be conducted on a digested sample by Inductively Coupled Plasma to detect metal components, and by X-ray Diffraction to identify the crystalline structure of the deposit. This will be of particular interest for analysis of any calcium salts precipitated, since many magnetic device manufacturers report formation of aragonite instead of calcite as a key to their effectiveness in reducing scale formation.

Following a complete evaluation of the water analysis, indices, and mineral scale formed in the test coupons and heat exchangers, conclusion will be reached regarding the effectiveness of the devices under the test conditions used.

**Table A1
Magnetic/Electrolytic/Electronic Devices**

Product Name	Principle	Product Name	Principle
Aqua-Aid	Magnetic	Electr-A-Sonic	Electrostatic-Ultrasonic
Aqua Cells	'Micromagnetic'	Electronic Water Treater	'Electron Generator'
Aqua Electric Scale Control	Electrolytic	Electro-Pure	Electrostatic
Aqua-Flo	Magnetic	Electrostatic Water Treater	Electrostatic
Aqua King	Sequestering Agent	Ener Tec	'Linear Kinetic Cell'
Aqua Magnetics	Magnetic	ESSA Static Water Probe	Electrostatic
Aquospace	Special Alloy-Fitting- Pressure Drop	EVIS	Catalytic
Aqua-Tec	Electrostatic	EWC 5000	Electromagnetic
Aqua-TRON	Electronic	Filter-All Electronic	Catalytic
Aquatronics	Electrostatic	Free-Flo	Catalytic
All-State Spacemaster	'Electronic Softener'	Fluid Stabilizer	Special Alloy-Filter
Ashbrook Water Stabilizer	Pressure Drop-Filter	Fluid-Tec	Magnetic
Beco-Cell	Electrolytic	Guldager Electrolyte	Electrolytic
Bon Aqua	Magnetic-Hydrostatic	Hako	Magnetic
Butler Electrostatic	'Electrolytic'	Hydro-Clean	Electrostatic-Magnetic
Care Free	Electro-mechanical	Hydrodynamics	Magnetic
CEPI	Magnetic	Hydro-Tron	Electrolytic
Chem-Free	Electrolytic	Ingersoll-Rand	Electrostatic
Colloid-A-Tron	Special Alloy-Pressure Drop	Ion Stick	Electrostatic
Corroscale Tool	Special Alloy Fitting- Pressure Drop	KDF Filters	Zinc/Copper Alloy
Crustex	Ultrasonic	Kemtune	Magnetic
Dehydrosal Systems	Electrolytic	Magnalawn 2000	Magnetic
Descal-A-Matic	Magnetic	MagnaFlo	Magnetic
Ecotec	Magnetic-Ozone- Electrolytic	Magnetizer	Magnetic
EJAX	Special Alloy-Fitting	Midland Pacific	Electronic

Table A1 (continued)

Product Name	Principle	Product Name	Principle
Natural Energizer	Pyramid Power	Softy	'Electronic Softener'
Nokem	Electromotive Force	SOLA	Catalytic
Paracat Water Stabilizer	Catalytic	Solavite	Catalytic
Petro-Mag	Magnetic	Sonic	Magnetic
Phillips	Electrostatic	Stain-Out	Magnetic
Power Management	Electrostatic	Sullelectron	Electronic
Pow-R-Cell	'Flux Force Field'	Superior	Magnetic
Progressive Electronic Water Treater	Electronic	Tampure	Silver Ion Release
SALMO Scale Inhibitor	Electronic	TPT Chelator	Softener
Scale Control Systems	Electrostatic	Transfer Rods	Electrostatic Grounding
Scalegon	Electronic	Turbomag	Electromagnetic
Scalemaster	Ultrasonic-Electrostatic	Ultrastat	Electrostatic
Scalewatcher	Electronic	Wateco	Electrostatic
Sentry EMTU	Electromagnetic	Water Energizer	'Resonance Energy Wave'
SFS Scale Free Systems	Electrolytic Grounding	Water Stabilizer	Catalytic
Softron	Magnetic	Worthington	Electrostatic

**Table A2
Water Chemistry Analyses**

Analyte	WTP Supply	Magnetic #1	Magnetic #2	Electronic	Control
Total Hardness (mg/L as CaCO ₃)					
Calcium Hardness (mg/L as CaCO ₃)					
Magnesium Hd. (mg/L as CaCO ₃)					
Total Alkalinity (mg/L as CaCO ₃)					
Temperature					
pH					
Total Dissolved Solids (mg/L)					
Conductivity					
Iron (mg/L as Fe)					
Copper (mg/L as Cu)					
Zinc (mg/L as Zn)					
Manganese (mg/L as Mn)					
Nitrate (mg/L as NO ₃)					
Phosphorus (mg/L as PO ₄)					
Sulfate (mg/L as SO ₄)					
Chloride (mg/L as Cl)					
Silica (mg/L as SiO ₂)					

APPENDIX B: Literature Search Bibliography

1. **So-called Electrical and Catalytic Treatment of Water for Boilers** Eliassen, Rolf and Uhlig, Herbert H., Journal American Water Works Association, Vol. 44, No. 7, p. 576-582, July 1952.
2. **Corrosion Control by Magic - It's Wonderful** Uhlig, Herbert H. Corrosion, Vol. 8, p.361-363, November 1952.
3. **Report to Water Conditioning Research Council on Water Conditioned by an EVIS Unit** Foster D., Snell Inc., July 1952.
4. **Practical Performance of Water-Conditioning Gadgets** Welder, B.Q. and Partridge, Everett P., Industrial and Engineering Chemistry, Vol. 46, p. 954-960, May 1954.
5. **Experimental Evaluation of 'Water Conditioner' Performance** Eliassen, Rolf and Skrinde, Rolf, Journal American Water Works Association, Vol. 49, No. 9, p.1179-1190, September 1957.
6. **Corrosion Engineering** Fontana, Mars G., and Greene, Norbert, R., McGraw-Hill, Inc., p. 197-198, 1967.
7. **Magnetic Treatment of Water and Aqueous Systems in Flotation and Thickening of Ores and Coals** Klassen, V.I., Proceedings VIII International Mineral Processing Congress, Leningrad, USSR, 1968.
8. **Electrostatic Descaler Testing: An Evaluation** Meckler, Milton, Heating, Piping & Air Conditioning, p. 37-40, August 1974.
9. **The Fatal Lure of Water Treating Gadgets** Dromgoole, J.C. and Forbes, M.C., Proceedings International Water Conference, November 1979.
10. **Water Conditioning Devices - An Update** Wilkes, J. Fred and Baum, Ray, Proceedings International Water Conference, November 1979.
11. **Magnetic Field Conditioning of Industrial Waters** Kvajic, George and Milosevic-Kvajic, Mirjana, Proceedings International Water Conference, November 1979.
12. **The Fatal Lure of Water Treating Gadgets** Dromgoole, J.C. and Forbes, M.C., Proceedings National Association of Corrosion Engineers Annual Conference, November 1979.

13. **Nonchemical Water Treating Devices** Wescott, Ralph M., *Materials Performance*, p. 40-42, November 1980.
14. **Efficiency of Some Physical Scale Prevention Methods in Thermal Desalination Plants** Martynova, O.I., *Proc. Int. Symp. Fresh Water Sea*, Vol. 7th, No. 1, p. 399-406, 1980.
15. **A Viable Approach to Water and Wastewater Treatment** Reimers, R.S., deKernion, P.S., Robedeau, F.C., and Leftwich, D.B., *Water Technology*, p. 44-65, May-June 1980.
16. **Prospects of Using Magnetic Wastewater Treatment** Klassen, V.I., State Scientific-Research Institute of Mining and Chemical Raw Materials, *Vodye Resursy* No. 4, p. 146-151, USSR, July-August 1981.
17. **Mechanical Devices for Water Treatment: Just How Effective are They?** Puckorius, P., *Power*, p. 60-62, January 1981.
18. **The Performance of a Magnetic Water Conditioner Under Accelerated Scaling Conditions** Hasson, D., Bramson, D., *Dep. Chem. Eng., Technion-Israel Inst. Technol.*, p. 217-273, 1981.
19. **Consulting Services Related to the Theory and Technology of Magnetic Water Treatment** Lane, Russell W., Contract Report for U.S. Army Construction Engineering Research Laboratory, 1981.
20. **Performance Analysis of Permanent Magnet Type Water Treatment Devices** Gruber, C.E., Carda, D.D., *Water Quality Association, Research Reports*, July 1981.
21. **Effect of Magnetic Field on Internal Corrosion of Water Pipelines** Das, C.R., Misra, H.P., *J. Inst. Eng.*, Vol. 63, No. 1, p.30-31, 1982
22. **Reviewing the Usage of Applied-Fields in Industrial Water Treatment-What Works? What Does Not Work?** Reimers, R.S., Anderson, A.C., White, L.E., *Proc. Int. Water Conf., Eng. Soc. West. Pa.* 44th, p. 280-291, 1983.
23. **A Review of Scale Formation and Scale Prevention, with Emphasis on Magnetic Water Treatment** Ellingsen, Frank, *Water Supply*, Vol. 1, No.2-3, 1983.
24. **Scale Prevention and Removal by Hydrodynamic Fluid Treatment** Davies, J.H., *Certif Eng.*, Vol. 56, No. 1, p. 4-10, January 1983.
25. **Corrosion and Deposit Control in Alkaline Cooling Water Using Magnetic Water Treatment at Amonco's Largest Refinery** Grutsch, James F. and McClintock, J. Warren,

- Proceedings National Association of Corrosion Engineers Annual Conference, April 1984.
26. **Magnetic Water Treatment Devices, The Results of a University Study** Busch, Kenneth W., Busch, et. al., Proceedings International Water Conference, October 1984.
 27. **Evaluation of Commercial Magnetic Descalers** Lawrence, Debbie J., U.S. Army Corps of Engineers Construction Engineering Research Laboratory Technical Report M-342, May 1984.
 28. **Laboratory Studies Involving Magnetic Water Treatment Devices** Busch, Kenneth W., Busch, et. al., Proceedings National Association of Corrosion Engineers Annual Conference, March 1984.
 29. **The Control of Scale and Corrosion in Water Systems Using Magnetic Fields** Raisen, Elliott, Proceedings National Association of Corrosion Engineers Annual Conference, April 1984.
 30. **Effectiveness of Magnetic Water Treatment in Suppressing CaCO₃ Scale Deposition** Hanson, D., Bramson, D., Ind. Eng. Chem. Process Des. Dev., Vol. 24, No. 3, p 588-592, 1985.
 31. **Tests of Non-Chemical Scale Control Devices in a Once-Through System** Limpert, G.J.C., and Raber, J.L., Proceedings National Association of Corrosion Engineers Annual Conference, March 1985.
 32. **Water Treatment Specification Manual** Rosa, Frank, McGraw-Hill, Inc., p. 190-191, 1985.
 33. **Quantitative Assessment of the Effectiveness of Permanent Magnetic Water Conditioning Devices** Alleman, James E., Water Quality Association, Research Reports, November 1985.
 34. **Experimental Evidence for Effects of Magnetic Fields on Moving Water** Kronenberg, Klaus, IEEE Transactions on Magnetics, Vol. Mag. 21, No 5., p. 2059-2061, September 1985.
 35. **Experimental Evidence for Effects of Magnetic Fields on Water** Kronenberg, Klaus J., Institute of Electric and Electronic Engineers Transactions on Magnetics, Vol. Mag. No. 5, p. 2059-2061, September 1985.
 36. **Magnetic Treatment Does Work** Carpenter, Roland K., Publ by NACE, p.252.1-252.8, March 1985.

37. **Magnetic Treatment of Scale Prevention and Descaling in Water Treatment and Process Systems** Donaldson, J.D., Prod Finish, Vol. 39, No. 9, p. 6-8, 10, September 1986.
38. **Studies of a Water Treatment Device That Uses Magnetic Fields** Busch, Kenneth W., Busch, et. al., National Association of Corrosion Engineers, Vol. 42, No. 4, p. 211-221, April 1986.
39. **Alkalinity - pH Changes with Temperature for Water in Industrial Systems** Emerson, G.D., Ellis Horwood Limited, 1986.
40. **Softening Hard Scale** Chynoweth, Emma, Process Eng, Vol. 68, No. 5, p. 77, 1987.
41. **Scale Prevention in Steel Pretreatment by Magnetic Treatment** Donaldson, John, Grimes, Sue, Steel Times Int., Vol. 11, No. 5, p. 44-45, 1987.
42. **Scale Prevention and Descaling** Donaldson, J.D., Tube International, p. 39-49, March 1988.
43. **Magnetic Field Effect on Crystals** Grimes, Sue M., Tube International, March 1988.
44. **Lifting the Scales From Our Pipes** Donaldson, John, Grimes, Sue, New Sci., Vol. 117, No. 1600, p. 43-46, 1988.
45. **Mechanistic Study of the Effects of Magnetic Fields on Scale Formation** Katz, Joseph L., The John Hopkins University, Progress Report, August 1988.
46. **Magnetic Water Treatment: The Effect of Iron on Calcium Carbonate Nucleation and Growth** Herzog, Ruth E., Shi, Qihong, Patil, Jay N., and Katz, Joseph L., Langmuir, Vol. 5, No. 3, p. 861-867, 1989.
47. **The Effect of Magnetic Fields on Calcium Carbonate Scale Formation** Dalas, Evengelos, Koutsoukos, G.J., Cryst. Growth, Vol. 96, No. 4, p. 802-806. 1989.
48. **Corrosion and Scaling in Water Supply Systems** Legrand, L. and Leroy, P., 1990.
49. **Who Knows the Secret of the Black Magic Tube?** Anon, Finishing, Vol. 14, No. 4, p. 27-28, April 1990.
50. **Magnetic and Electrostatic Methods of Water Treatment** Silman, Harold, Met. Finish, Vol. 88, No. 8, p. 19-20, 1990.
51. **Environmental Engineering 1991** Krenkel, Peter A., Proceedings National Association of Corrosion Engineers Annual Conference, Proceedings of the 1991 Specialty Conference,

- 1991.
52. **Magnetic Water Treatment** Russian Paper, Fluid-Tech International, 1992.
 53. **Soviet Work in the Area of Non-Chemical Fluid Treatment** Russian Paper, Fluid-Tech International, 1992.
 54. **Growing Attraction of Magnetic Treatment** Spear, Mike, Process Eng, Vol. 73, No. 5, p. 143 May 1992.
 55. **Water Hardness** Russian Paper, Fluid-Tech International, 1992.
 56. **Insulating Properties of Scale** Russian Paper, Fluid-Tech International, 1992.
 57. **Non-Chemical Scale Control Devices** Limpert, G.J.C., and Raber, J.L., AWT Analyst, p 3- 11, July 1992.
 58. **Studies of Some Properties of Magnetically Treated Water** Li, Dexin, et. al., Proc. Int. Symp. Phys. Magn. Mater., 2nd Vol 2, p. 809-812, 1992.
 59. **Magnetic Treatment of Water - A Theoretical Quantum Model** Srebrenik, S., **Magnetic and Electrical Separation**, Vol 5, No. 2, p. 71-91, 1993.
 60. **Calcite Growth Inhibition by Iron** Katz, J.L., Reick, M.R., Herzog, R.E., Parsiegla, K.I., Langmuir, Vol. 9, No. 5, p. 1423-1430, 1993.
 61. **Control of Scale and Corrosion in Building Water Systems** Lane, Russell W., McGraw-Hill Inc., p. 181-182, 1993.
 62. **Effects of a Magnetic Field on the Formation of CaCO₃ Particles** Higashitani, Ko, et. al., Journal of Colloid and Interface Science, Vol. 156, p. 90-95, 1993.
 63. **Effect of Magnetic Field on Evaporator** Cole, Frank, Clarke, Margaret A., Proc. Sugar Process. Res. Conf., p. 64-68, 1993.
 64. **Magnetic Water Treatment for Scale Prevention** Lipus, L., Krope, J., Garbai, L., Hung. J. Ind. Chem, Vol. 22, No. 4, p. 239-242, 1994.
 65. **Electromagnetic Water Conditioners are Soft Option** H&V Engineer, Vol. 67, No. 724, p. 12-13, 1994.
 66. **Calcite Growth and the Inhibiting Effect of Iron (III)** Takasaki, S., Parsiegla, K., Katz, J.L., Journal of Crystal Growth, Vol. 143, p. 261-268, 1994.

67. **Point-of-Use Treatment. Experience with Physical Water Conditioners in the Netherlands** Van Den Hoven, Th. et.al., Kiwa NV, Nieuwegein, 1994.
68. **Water Treatment - The Soft Option** Anon, H&V Engineer, Vol. 67, No. 722, p. 6-8, 1994.
69. **Magnetic Treatment of Water and Scaling** Paiaro, Sastone, Pandolfo, Luciano A n n . Chim, Vol. 84, No. 5-6, p. 271-274, 1994.
70. **Water Quality Association Position Paper on Catalytic, Electromagnetic, and Magnetic Devices Claimed to Treat Drinking Water**, revised July 1994.
71. **Prevention & Control of Water-Caused Problems in Building Potable Water Systems** TPC Publication 7 2nd Edition, NACE International, 1995.
72. **Consumer Alert: Magnetic Water Treatment Devices Do Not Work** Giani, Francine, News Release, Division of Drinking Water, State of Utah, March 15, 1995.
73. **Benefits of Permanent Magnets in Factory Evaporation** Cole, Frank, Clarke, Margaret A., Int. Sugar J., Vol. 98, No. 1166, p. 71-72, 1996.
74. **Magnetic Amelioration of Scale Formation** Baker, John S., and Judd, S.J., Wat. Res., Vol. 30, No. 2, p. 247-260, 1996.
75. **The Role of Zinc in Magnetic and other Physical Water Treatment Methods for the Prevention of Scale** Coetzze, P.P., Yocoby, M., Howell, S., Water SA, Vol. 22, No. 4, p. 319-326, 1996.
76. **Magnets That Don't Do Much to Soften Water** Consumer Reports, p. 8, February 1996.
77. **Magnetically - Enhanced Chemical Disinfection** Ifill, A.S., Baker, J.S., Jud, S.J., Process Safety and Environmental Protection: Transactions of the Institution of Chemical Engineers, Part B Vol. 74, No. 2, May 1996.
78. **Rapid Onset on Calcium Carbonate Crystallization Under the Influence of a Magnetic Field** Wang. Y., Babchin, A.J., Chernyl, L.T., Water Res., Vol. 31, No. 2, p. 346-350, 1997.
79. **Theory of Electronic Anti-Fouling Technology to Control Precipitation Fouling in Heat Exchangers** Cho, Young I., Fan, Chunfu, Choi, Byung-Gap, Int. Comm. Heat Mass Transfer, Vol. 24, No. 6., p. 757-770, 1997.
80. **Using Magnetic Fields to Prevent Scale** Benson, Robert, et. al., Chemtech, Vol. 27, No. 4, p. 34-38, 1997.

81. **Laboratory Studies on Magnetic Water Treatment and their Relationship to a Possible Mechanism for Scale Reduction** Busch, Kenneth W., Busch, Marianna A., Desalination, Vol. 109, No. 2, p. 131-148, 1997.
82. **Control Factors in Performance Testing of Nonchemical Water Treatment Devices** NACE Technical Committee National Association of Corrosion Engineers, reaffirmed 1997.
83. **Magnetic Treatment of Calcium Carbonate Scale-Effect of pH Control** Parson, S.A., Bao-Lung, W., Judd, S.J., Stephenson, T., Wat. Res., Vol. 31, No. 2, p. 339-342, 1997.
84. **Basics of Magnetism** Webster, H.A., Correng Publications Service Inc., T-7, p. 1-12, September 1998.
85. **Magnetic Water Treatment for Scale Prevention** Lipus, L., Krope, J., Garbai, L., Hung. J. Ind. Chem, Vol. 26, No. 2, p. 109-112, 1998.
86. **Synergistic Application of Chemical and Electromagnetic Water Treatment in Corrosion and Scale Prevention** Colic, Miroslav, Chien, Allen, Morse, Dwain, Croatian Chemical Society, 1998.
87. **Do Magnetic and Electromagnetic Water Conditioners Work?** Henke, Larry, Water Conditioning & Purification, p. 70-74, July 1998.
88. **Removal of Iron From Sodium Fluorosilicate Scale by Magnetic Treatment** Wang, Chuha, Benson, R., Martin, Dean F., Fla. Sci, Vol. 61, No. 2, p. 88-95, 1998.
89. **Standards for Magnetic Devices Still Seem a Long Way Off** Cummings, Sean, Water Technology, pp 37-42, April 1998.
90. **Predictably Effective Equipment and In Situ Processes Applied to Water Systems** NACE Technical Committee Proceedings National Association of Corrosion Engineers Annual Conference, June 1998.
91. **The Role of Chemical Constituents and Their Effects on Scale Inhibition Following Magnetic Treatment** Reimers, Robert S., Shariat, S.D., Carpenter, Roland K., and Akers, Thomas R..
92. **Magnetic Water Treatment De-Mystified** Kronenberg, Klaus J., Magnets, p. 6.
93. **Non-Chemical Technologies for Scale and Hardness Control** U.S. Department of Energy DOE/EE-0162.

94. **Magnetically Augmented Water Treatment** Parson, S.A., Bao-Lung, W., Judd, S.J., Udol, K., School of Water Sciences, Cranfield University.
95. **Measurements of Magnetic Effects on Electrolyte Solutions by Atomic Force Microscope** Higashitani, Ko, et. al., Department of Chemical Engineering, Kyoto University.
96. **Non-Chemical Water Treatment Technology in Energy Savings Performance Contracting** Soloman B. Williams, Tyndal AFB FL.

APPENDIX C

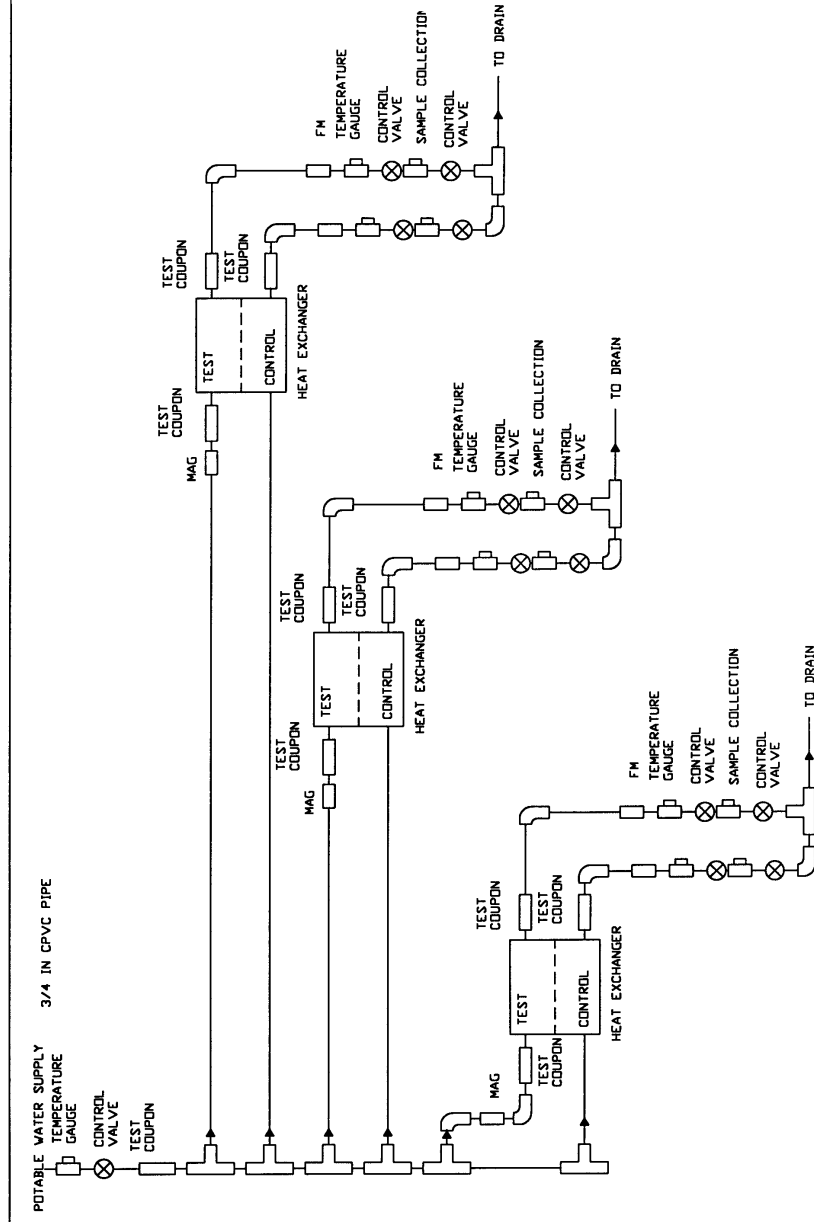

TEST SPECIFICATIONS FOR MAGNETIC DESCALERS

4 loops - 1 control and 1 with each of three magnetic descaling device

Descal-A-Matic – permanent

Aqua Magnetics – permanent

Enertech – electromagnetic

Potable Water System

Steam heat exchanger

Heat water to 130 – 140 degrees F

Monitor and Control Flow Rate and Temperature

Flow Rate 2 – 3 gpm could go up to 8 – 10 gpm if needed

Send to Waste

Descal-A-Matic

757 858-5593

In Stock

Contact: Ernie Florestano or Norman Powers

Permanent Magnet No Power Required

Material Does not matter PVC or Copper or Stainless Steel

Copper would need additional parts Dielectric Unions

16.75 X 1.25 IN

Built-in Flow control

Must be mounted vertically

Up to 180 psi

Up to 400 degrees F

DC – 6 \$650

6 gpm

DC – 12 \$1090

D-A-M suggests this one

12 gpm

We will let them review test plan and make suggestions

Tech Manual

Would like to assist in the process

Aqua Magnetics

800 328-2843

<http://www.aqua.magnetics.com>

In Stock

2.125 X 1.25 X 2.5 IN

Horizontal or Vertical
PVC or Copper
Concerned with the flow rate being too low
Permanent Magnet No Power Required
Up to 212 degrees F
\$29.95

Magnatech

No
Scott Sanderson
800 692-1123

Enecon

<http://enecon.com>
no power
Mike Tedesco

Enertech

517 741-5015
Electromagnetic
Flow rate not an issue
\$1500
model 750
115 VAC power supply
16 X 3 X 4 IN

Amendments to the Test Plan

07/13/99

TO: Nelson Labbe, CEMP - EC

FROM: Vince Hock , CEERD - CF - M

(Amended) Test Plan for Magnetic Descaler Demonstration and Evaluation To Be Conducted at Rock Island Arsenal

SITE VISIT

June 14, 1999, Location: Water Treatment Plant at Rock Island Arsenal

A site visit was conducted by CERL and ISWS to determine if the water quality at the Rock Island Arsenal would be suitable for scale build-up and to evaluate the water treatment plant location for conducting the demonstration of magnetic descalers. The water quality was determined to be suitable for scale build-up with a total hardness level of 240 mg/L CaCO₃ consisting of 160 mg/L Calcium Hardness as CaCO₃ and 80 mg/L Magnesium Hardness as CaCO₃. The Alkalinity was found to be 135 mg/L as CaCO₃ and the pH was found to be 7.7.

POCs at Rock Island Arsenal

Chuck Swynenberg Dave Osborn
309 782-2445 309 782-2393

POC at Illinois State Water Survey:

Kent Smothers
217 333-6167

Test Specifications for Magnetic Descalers:

- 8 Test Loops through 4 Steam Heat Exchangers (2 per H.E)
- Each Heat Exchanger will have 1 Control Loop and 1 Test Loop
- 3 will be using the Magnetic Descaling Devices and the fourth will be softened water.
- Potable Water System
- Steam Heat Exchangers
- Flow Rate: 2 - 3 gal per min

- Materials of Construction: PVC Piping
- Effective Temperature Range: 130 - 140 degrees F
- Monitor and Control Flow Rate and Temperature could go up to 8 - 10 gpm if needed
- Send to Waste
- Descal-A-Matic - permanent magnet
- Aqua Magnetics - permanent magnet
- Enertech - electromagnetic

MAGNETIC DESCALER MANUFACTURERS AND PRODUCT INFO:

Descal-A-Matic

757 858-5593

757 853-3321 FAX

POC: Ernie Florestano or Norman Powers

Product: Fluid Conditioner

Model DC - 6

- Dimensions: 16.75 X 1.25 X 1.25 IN
- \$650
- Vertical Placement only
- Acceptable Pipe Materials: PVC or Copper or Stainless Steel
- Copper would need additional parts - Dielectric Unions
- Built-in Flow control
- Maximum 6 gal per min Flow Rate
- Permanent Magnet: No Power Required
- Up to 180 psi
- Up to 400 degrees F

Also Model DC - 12 , \$1090, 12 gal per min

Enertech

517 741-5015

517 741-3474 FAX

POC: Larry Shroyer

Product: Linear Kinetic Cell**Model 750 P**

- Dimensions: 16 X 3 X 4 IN
- \$1500
- Acceptable Pipe Materials: PVC
- Also model 750 C - For Copper
- Flow rate not an issue for product
- Electromagnetic
- 115 VAC power supply

Aqua Magnetics

800 328-2843

727 726-8888 FAX

POC: Roland Carpenter

<http://www.aqua.magnetics.com>

Product: Water Activator II

- Dimensions: 2.125 X 1.25 X 2.5 IN
- \$29.95
- Horizontal or Vertical Placement
- Acceptable Pipe Materials: PVC or Copper
- Permanent Magnet: No Power Required
- Up to 212 °F

Appendix C: Comments and Responses to the Field Test Work Plan

August 13, 1999

Materials & Structures Branch

Mr. Roland Carpenter
Aqua-Magnetics
915-C Harbor Lake Drive
Safety Harbor, Florida 34695

Dear Mr. Carpenter:

Thank you for your comments on the U.S. Army Construction Engineering Research Laboratory (CERL's) Magnetic Descaler Test Plan. The enclosure contains our response to your comments.

In addition, the following water chemistry is provided:

Hardness: Total = 240 mg/L as CaCO₃
Calcium = 160 mg/L
Magnesium = 80 mg/L
Alkalinity = 135 mg/L as CaCO₃
pH = 7.7

If you have any questions, please call me at 1-800-USACERL Ext. 6753 or Brian Gard at Ext. 7635. Thank you for providing valuable comments regarding CERL's Test Plan.

Sincerely,

Vincent F. Hock

Enclosure

Copy Furnished:

Nelson Labbe

ENCLOSURE

1. Performance is not defined for Magnetic Descalers.

a. I would define performance as the capability to break up Suspended particles in the water such that scale does not form. This can be done with a particle distribution counter and plot the particle distribution before and after treatment. Because this is the only thing that changes in the water, chemical measure data reveals nothing.

The performance of the Magnetic Descalers will be evaluated by the inspection of the test coupons and the surface of the heat exchanger tube. The amount of scale formed and the corrosion rate will be compared against a control. CERL has asked the Illinois State Water Survey for information regarding particle distribution counters.

2. Installation parameters are not defined for magnetic descalers.

a. For the model that you have ordered, install on non-magnetic pipe about 15 pipe diameters prior to entering appliance.

We will ensure a minimum of 15 pipe diameters (12 inches) prior to entering the appliance. The unit will be installed in non-magnetic pipe (CPVC).

3. Velocity of fluid not defined.

a. For our units, a minimum water velocity of 1 ft/sec is required when water is passing through the unit. Other manufacturers have their velocities. Gallons per minute without pipe size does not answer this question.

The pipe diameter was defined to be ¾" throughout the test. This corresponds to an anticipated velocity of 2 ft/sec (3 gpm). Thus the minimum velocity of 1 ft/sec will be exceeded at all times.

4. Magnetochemistry of the water is not defined.

a. A magnetic susceptibility analysis of the water indicating the paramagnetic and diamagnetic molecules in the water and their quantity to determine net magnetic value of the water,

The supply is finished potable water, whose original source is the Mississippi River. We have included some basic water quality information in the cover letter.

5. Corrosion coupon location not defined.

a. Corrosion coupons should be located where the water velocity is 1 ft/sec Min to prevent the deposits. Yes there are two velocities to be concerned with in the installation. The worst place is inside the water heater where velocity is near zero.

The corrosion/scale coupons will be placed at locations where the flow rate is 3 gpm. The flow rate throughout the test loop is 3 gpm. Again, this translates into a velocity of about 2 ft/sec for the pipe size used. The flow rate will be monitored after the heat exchangers, thus ensuring the proper flow rate at the location of the corrosion/scale coupons.

6. Location of units for water heater installation not specified.

a. For water heaters, two of our units are recommended. One 15 pipe diameters prior to inlet and one on the outlet pipe (straight pipe) prior to be used.

This is not a home type water heater, but a heat exchanger with a constant flow rate. We are more interested in simulating institutional building use, since that would be of the most concern to the Army. When we explained the design and intent originally, we were informed this unit would work for the flow rate and purpose we had selected. Also, since we are routing the water to waste after the heater, I do not think this should be an issue. A unit installed after the heater should not affect performance in the heater. However, we have ordered an additional unit as per your request and we will install it as per your request.

August 13, 1999

Materials & Structures Branch

Mr. Larry Shroyer
Ener-Tec
PO Box 85
Union City, Michigan 49094

Dear Mr. Shroyer:

Thank you for your comments on the U.S. Army Construction Engineering Research Laboratory (CERL's) Magnetic Descaler Test Plan. The enclosure contains our response to your comments.

In addition, the following water chemistry is provided:

Hardness: Total = 240 mg/L as CaCO₃
Calcium = 160 mg/L
Magnesium = 80 mg/L
Alkalinity = 135 mg/L as CaCO₃
pH = 7.7

If you have any questions, please call me at 1-800-USACERL Ext. 6753 or Brian Gard at Ext. 7635. Thank you for providing valuable comments regarding CERL's Test Plan.

Sincerely,

Vincent F. Hock

Enclosure

Copy Furnished:

Nelson Labbe

First of all, Ener-Tec, Inc. does not manufacture or recommend electromagnetic water treatment systems for home use since there is very little flow, in fact most of the time there is no flow.

In response to the flow rate, the anticipated flow rate is 3 gpm. A constant flow will be maintained throughout the test. This test flow rate was certified by Ener-tec, Inc. as acceptable prior to the purchase of the unit.

Secondly, conducting the test with a steam fed heat exchanger does NOT simulate a domestic application in anyway. We don't recommend our system in industrial applications where super heated steam is used due to the tremendous amount of turbulence that takes place within the system. You should be aware that polarization can be destroyed by either heating or beating. This is true in liquids or solids. This is a simple law of physics.

We are simulating hot water systems. The U.S. Army has thousands of hot water system in dorms, office buildings, etc. that use steam as a heat source in shell and tube heat exchangers around the world. It is very common in multiple story apartment buildings as well. Superheated steam is used to turn turbines, etc. Superheated steam would never be used in a heat exchanger. Since there is little water the heat transfer is very poor. There is no superheat to this steam. The steam used for this purpose is typically 5-15 psig, low-pressure steam. Turbulence should not be a problem either, as the steam does not directly contact the water.

Our equipment is used for industrial applications such as cooling towers, water cooled air compressors, heat exchangers (non steam), chillers, water misting systems, spray systems, heat treat furnaces, etc.

This application is designed to test suitability for institutional use, not homes. Domestic hot water merely refers to potable water that is heated for the purposes of showers, kitchen and laundry use, etc.

The problem in the past has been those manufacturers that recommend the equipment for every application, not knowing or admitting to knowing the limitations. This is not only true on our type equipment but also in R.O., filtration, ionization, etc. If you are going to simulate an actual domestic application you should utilize equipment found in the home such as ice makers, hot water heaters (conventional domestic), dish washers, shower nozzles, and any other domestic appliance that uses water.

Again, this test is for institutional suitability. The Army is not testing the suitability of magnetic descaler units for household application at this time.

Testing should also be conducted with raw well or city water, not softened or deionized.

Apparently there was some misunderstanding about the water supply, our intent has always been to use finished potable water, which has not been softened or deionized. See water quality information in cover letter.

September 9, 1999

Materials and Structures Branch

Mr. Ernie Florestano
Mr. Norman Powers
Descal-A-Matic
4855 Brookside Court
Norfolk, Virginia 23502

Dear Mr. Florestano and Mr Powers:

Thank you for your comments on the U.S. Army Construction Engineering Research Laboratory (CERL) Magnetic Descaler Test Plan. The enclosure contains our response to your comments.

In addition, the following water chemistry is provided:

Hardness:	Total	= 240 mg/L as CaCO ₃
	Calcium	= 160 mg/L
	Magnesium	= 80 mg/L
Alkalinity		= 135 mg/L as CaCO ₃
pH		= 7.7

If you have any questions, please call me at 1-800-USACERL Ext. 6753 or Brian Gard at Ext. 7635. Thank you for providing valuable comments regarding the CERL Test Plan.

Sincerely,

Vincent F. Hock

Enclosure

Copy Furnished:

Nelson Labbe

1. *The next to the last sentence in ABSTRACT states that "These alternatives purport to use electric or magnetic fields to change chemical and physical conditions in the water in such a way as to prevent mineral scale buildup." Our Comment on this is that Descal-A-Matic Corp. has never and does not claim to change chemical conditions in the water. Water before entering the DescalA-Matic Unit and after leaving the Unit should be exactly the same chemically. We add nothing to the water and take nothing away from the water. The D-A-M effect is strictly a physical one and not a chemical change. Our detractors over the years have purported to claim that since a chemical change has not occurred, nothing has happened. If this line of thinking is to be injected into the proposed test plan, then we will have no part in it.*

The text was changed to "chemical or physical conditions." While your product does not claim to change chemical conditions, others have.

2. *Again, on page 5 of the work plan, under INTRODUCTION, Background, in the first paragraph, last sentence; the-authors suggest that our magnetic treatment purports to change chemical and physical conditions in the water. 'We do not purport to change any chemical conditions.*

Again, the text was changed to "chemical or physical conditions."

3. *Paragraph two on page 5 refers to the 1984 CERL Technical Report M-342. You know how I feel about how that test was poorly conducted and was doomed to failure from the outstart. The fact that it was commented upon suggests to us a negative attitude before proceeding objectively with the new test plan.*

We are not prepared to remove this from the test plan.

4. *The next paragraph, paragraph three on page 5 continues with negative reporting. Correction, the study was not conducted at Tyndall AFB in Florida. It was administered by HQ AFCESA/CESE at-Tyndall AFB under the auspices of the MEEP Management*

Office at Elgin AFB. However, the actual testing was conducted at Langley AFB here in Virginia. Descal-A-Matic people were very involved in this test. It was a resounding success, based on our personal observation of the corrosion coupons that were turned over to the people at Tyndall AFS. However, the record keeping on their part was indeed insufficient. The crowning blow came when we were advised that LtCol Michael Kaminkas sent the corrosion coupons to the BETZ CHEMICAL COMPANY's laboratory for evaluation. And guess what? BETZ claims to have LOST the coupons. Of course they did, because we saw how pristine they looked at the end of the test with Descal-A-Matic treatment on a cooling tower system at Langley AFB.

From the report at Tyndall AFB: "Due to Air Force downsizing (right sizing) and lack of technical expertise in this specialized area of testing, the protocol used at Langley, Tyndall, and other locations is deemed insufficient to accurately evaluate the performance of these devices for use by the Air Force. Review of system operating parameters does not conclusively indicate benefits derived from non-chemical device usage. The data collected is most applicable as alarm indicators for the equipment operators, in order to further investigate variations in performance."

5. *At the bottom of page 5, under "Objective", the first word of the last line should be preventing and not "prevented".*

The error was corrected.

6. *I have personally sent to you reams of positive reporting on the successes of Descal-A-Matic during the past 29 years that we have been in business. None of this information appears in the ABSTRACT or INTRODUCTION to this new test procedure. For example, the AMSCO field "report" conducted four years ago in Platte, SD because that was the worst water condition that AMSCO could find in the USA with which to test our Descal-A-Matic equipment, was not cited. They were getting 3 to 4 weeks life out of the heating element in their sterilizer in the hospital at Platte. Next month will be FOUR YEARS since the D-A-M Unit (Model DC-12) was installed and they have yet to have to*

replace the heating element. Would it not have been fair and objective to have made mention of this documented success in the Introduction to the test plan??

Instead, in paragraph three on page 6 of the proposed test plan, the negative aura continues. The use of the words "pseudoscientific principles" to describe magnetic devices is derogatory as well as negative. The further reference to negative impressions by referring to the MIT papers is truly unforgivable. We wrote to the Chancellor at MIT some ten years ago about those papers and were advised as follows: The value of a paper written over 40 years ago should be considered as being not valid in today's environment. Also, none of the people who authored that paper are now on our staff. That was in the late 1980's.

Further in paragraph three, it is stated that "Authors of books on corrosion engineering and corrosion control consistently admonish consumers to regard any of these products with extreme caution". I agree with that advice completely. However, I have sent to you actual reports of a number of corrosion coupon test reports wherein the D-A-M treatment has outperformed chemical corrosion inhibitors. Typically we equal the chemical corrosion inhibitor's results. Why was some of that information not cited by the authors of the proposed test?

If you have any documentation from a respected journal and would like it included in our final report, please send us a copy of the report along with a proper citation of the article. We also changed the text "pseudoscientific principles" to "unscientific principles."

7. Please, let us go back again to the last line in paragraph one on page 5 of the INTRODUCTION, Background:

The very last line of that paragraph states "and control algae and bacteria". We make no such claim with our magnetic device. We definitely do claim to control those items, however. But with our CopperSilver Ionizer System. Not with our magnetic treatment. This statement by the authors is a generalization.

The text states "as to perform one or all of the following functions: prevent mineral scale buildup, remove existing scale, inhibit corrosion, and control algae and bacteria." We do not claim that every product performs all of these functions.

8. On page 7, in the next to the last line of paragraph three, the word "water" needs to be inserted between the words hot and distribution, so that the statement reads, "... scale formation under operating conditions typical of hot "water" distribution systems in institutional systems."

The error was corrected.

9. TEST PROCEDURE

Reference is made on page 7 to the test heat exchangers, We would like to know if these are to be "plate and fin" type heat exchangers or "shell and tube" type heat exchangers?

The heat exchangers are "shell and tube" type heat exchangers.

10. Also, what is the design flow rate through the Heat Exchangers? This information is especially important for us to know in order to be able to predict the successful performance of our Descal-A-Matic treatment.

The flow rate throughout the test is 2 gpm. The pipe diameter through the heat exchangers was defined to be 5/8". This corresponds to an anticipated velocity of 1.72 ft/sec. The velocity through the Descal-A-Matic unit was 1.3 ft/s.

11. Please clarify for us whether the test systems are circulating loops or straight through systems. This is crucial to our sizing and locating of the Descal-AMatic Unit to ensure its successful performance. The Appendix C schematic clearly indicates that they are straight-through systems. However, the language in the description on page 7, paragraph one, under TEST PROCEDURE, refers to loops, "...a test loop and a control loop." The word loop to us suggests that the water is to be re-circulated. We need to know for certain about this. When my associate Mr. Norman Powers and subsequently I talked with Mr. Brian Gard about this proposed test over the phone, both Norman and I had the impression that the test systems were to be re-circulating loops. That is why I agreed to use the Model DC-6 smaller Unit instead of my initial proposal to use the larger Model DC-12 Unit. As I have indicated in item #6 above in this letter, a Model

DC-12 Unit was used in the AMSCO test in Platte, SO, wherein they have experienced such dramatic good results with controlling scale.

The test system is a straight – through system. The term loop is meant to describe the path that the water takes from the potable supply to the drain. The only concern that was expressed to CERL was the maximum flow rate. By this time it was established that the system was not recirculating, but was straight through system.

12. Please refer to Appendix C, the schematic. The distance between the magnetic unit and the first test coupon (before the heat exchanger) is not indicated. In the case of our Descal-A-Matic Unit, this distance must be a minimum of 36 inches.

The distance between the Descal-A-Matic Unit and the test coupon is greater than 36”.

13. The last sentence of the first paragraph under TEST PROCEDURE on page 7 states that "Tests will be conducted for three to four weeks, or until such time as scale formation results in inadequate flow through the test unit." This is an inadequate length of time to get a valid test on the performance of the DescalA-Matic Unit as a corrosion inhibitor. We need 60 days and ideally 90 days to establish the protective aragonite coating on the test coupons. We are not at all concerned with scale formation. Referring again to the AMSCO test in Platte, SD, the DC-12 Unit has performed especially well in controlling scale for almost four years now. Before the D-A-M Unit was installed, they were scaling-out in three weeks.

At this time we are only testing the magnetic descaling units as scale prevention devices and not as a corrosion inhibitor. We will consider rerunning the test for a longer period of time after the conclusion of this test.

Appendix D: Operational Data

Table D1. Magnetic/electrolytic/electronic devices.

Product Name	Principle of Operation	Product Name	Principle of Operation
Aqua-Aid	Magnetic	Electr-A-Sonic	Electrostatic-Ultrasonic
Aqua Cells	'Micromagnetic'	Electronic Water Treater	'Electron Generator'
Aqua Electric Scale Control	Electrolytic	Electro-Pure	Electrostatic
Aqua-Flo	Magnetic	Electrostatic Water Treater	Electrostatic
Aqua King	Sequestering Agent	Ener Tec	'Linear Kinetic Cell'
Aqua Magnetics	Magnetic	ESSA Static Water Probe	Electrostatic
Aquaspace	Special Alloy-Fitting-Pressure Drop	EVIS	Catalytic
Aqua-Tec	Electrostatic	EWC 5000	Electromagnetic
Aqua-TRON	Electronic	Filter-All Electronic	Catalytic
Aquatronics	Electrostatic	Free-Flo	Catalytic
All-State Spacemaster	'Electronic Softener'	Fluid Stabilizer	Special Alloy-Filter
Ashbrook Water Stabilizer	Pressure Drop-Filter	Fluid-Tec	Magnetic
Beco-Cell	Electrolytic	Guldager Electrolyte	Electrolytic
Bon Aqua	Magnetic-Hydrostatic	Hako	Magnetic
Butler Electrostatic	'Electronolytic'	Hydro-Clean	Electrostatic-Magnetic
Care Free	Electro-mechanical	Hydrodynamics	Magnetic
CEPI	Magnetic	Hydro-Tron	Electrolytic
Chem-Free	Electrolytic	Ingersoll-Rand	Electrostatic
Colloid-A-Tron	Special Alloy-Pressure Drop	Ion Stick	Electrostatic
Corroscale Tool	Special Alloy Fitting-Pressure Drop	KDF Filters	Zinc/Copper Alloy
Crustex	Ultrasonic	Kemtune	Magnetic
Dehydrosal Systems	Electrolytic	Magnalawn 2000	Magnetic
Descal-A-Matic	Magnetic	Magnaflor	Magnetic
Ecotec	Magnetic-Ozone-Electrolytic	Magnetizer	Magnetic
EJAX	Special Alloy-Fitting	Midland Pacific	Electronic

Product Name	Principle of Operation	Product Name	Principle of Operation
Natural Energizer	Pyramid Power	Softy	'Electronic Softener'
Nokem	Electromotive Force	SOLA	Catalytic
Paracat Water Stabilizer	Catalytic	Solavite	Catalytic
Petro-Mag	Magnetic	Sonic	Magnetic
Phillips	Electrostatic	Stain-Out	Magnetic
Power Management	Electrostatic	Sullelectron	Electronic
Pow-R-Cell	'Flux Force Field'	Superior	Magnetic
Progressive Electronic Water Treater	Electronic	Tarnpure	Silver Ion Release
SALMO Scale Inhibitor	Electronic	TPT Chelator	Softener
Scale Control Systems	Electrostatic	Transfer Rods	Electrostatic Grounding
Scalegon	Electronic	Turbomag	Electromagnetic
Scalemaster	Ultrasonic-Electrostatic	Ultrastat	Electrostatic
Scalewatcher	Electronic	Wateco	Electrostatic
Sentry EMTU	Electromagnetic	Water Energizer	'Resonance Energy Wave'
SFS Scale Free Systems	Electrolytic Grounding	Water Stabilizer	Catalytic
Softron	Magnetic	Worthington	Electrostatic

Table D2. Rock Island Arsenal cold distribution.

Date	09/03/99	09/09/99	09/22/99	10/01/99	10/08/99	10/15/99	11/02/99
M Alkalinity (as CaCO ₃)	138	134	140	136	144	142	148
Hardness (as CaCO ₃)	206.7	207.8	220.1	213.6	224.2	220.9	210.0
Calcium (as Ca)	54.80	55.10	56.20	53.80	57.50	56.20	50.20
Magnesium (as Mg)	16.20	16.30	18.50	18.40	18.70	18.70	17.60
Sulfate (as SO ₄)	55	57	52	48	50	55	46
Chloride (as Cl)	25	24	35	31	32	26	25
Nitrate (as NO ₃)	7.3	6.7	6.5	6.3	6.2	6.1	6.0
Iron (as Fe)	0.01	0.00	0.00	0.00	0.00	0.00	0.03
Copper (as Cu)	0.00	0.00	0.03	0.01	0.00	0.00	0.00
Zinc (as Zn)	0.00	0.00	0.00	0.00	0.00	0.00	0.00
Sodium (as Na)	10.0	10.3	10.7	10.7	11.3	10.9	12.0
Manganese (Mn)	0.007	0.004	0.006	0.005	0.006	0.005	0.008
Total Dissolved Solids	272	276	313	270	265	282	258
pH	7.61	7.69	7.64	7.71	7.72	7.86	7.71
Temperature (°C)	27.0	27.2	22.1	20.6	17.7	17.7	15.1
Silica (as SiO ₂)	9.6	9.3	9.2	7.3	7.7	7.8	7.1
Ammonia (as NH ₄)	3.9	4.0	8.1	6.8	4.6	4.0	2.3
Conductivity (µS/cm)	453	459	505	517	544	476	472

Results are mg/L except for conductivity, pH, and temperature. No significant amount of phosphate was found in any of the samples.

Table D3. Daily operational log sheets.

Date/Time	Incoming Water Temp °F	Ener -Tec DC Amps	Supply Steam PSIG	HE #1Water Temp °F		HE #1Flow Rate GPM		HE #2Water Temp °F		HE #2Flow Rate GPM		HE #3Water Temp °F		HE #3Flow Rate GPM	
				Mag	Ctrl	Mag	Ctrl	Mag	Ctrl	Mag	Ctrl	Elect	Ctrl	Elect	Ctrl
09/01/99 3:00 p.m.	78	0.6	80	124	126	2.0	2.0	122	122	2.0	2.0	125	125	2.0	2.0
09/01/99 6:00 p.m.				Two lines to Heat Ext. broke											
09/02/99 3:45 p.m.	78	0.6	98	137	138	2.0	1.9	143	142	1.8	1.8	150	156	1.8	1.8
09/03/99 4:30 p.m.	78	0.6	112	146	150	1.9	1.8	154	150	1.8	1.9	140	148	2.0	1.9
09/04/99 3:00 a.m.	78	0.6	118	130	128	2.1	1.8	131	131	1.9	2.0	130	133	1.8	2.0
09/04/99 10:30 a.m.	78	0.6	112	120	120	2.0	2.0	125	125	2.0	2.0	124	125	2.0	2.0
09/04/99 4:40 p.m.	79	0.6	119	160	158	1.8	1.2	130	132	1.9	1.9	130	136	1.8	1.8
09/05/99 3:00 a.m.	79	0.6	123	127	126	1.7	2.2	125	126	1.9	1.9	140	120	1.7	2.2
09/05/99 12:00 p.m.	79	0.6	122	120	124	1.8	2.5	122	122	2.0	2.0	135	116	2.0	2.0
09/05/99 7:30 p.m.	79	0.5	124	118	127	2.0	2.0	125	127	1.8	1.8	139	118	2.0	2.5
09/05/99 1:30 a.m.	78	0.6	117	116	124	1.9	1.7	120	122	1.9	1.8	138	122	2.0	1.9
09/06/99 9:30 a.m.	79	0.6	120	120	120	1.9	1.8	120	120	1.9	1.8	135	128	2.0	1.1
09/06/99 7:00 p.m.	78	0.6	122	124	122	1.8	1.8	124	122	1.5	1.5	132	120	2.0	2.0
09/07/99 1:30 a.m.	77	0.6	120	114	116	2.0	2.0	120	120	2.0	2.0	138	124	2.0	2.0
09/07/99 1:00 p.m.	79	0.6	118	126	136	2.0	2.0	122	122	2.0	2.0	130	120	2.0	2.0
09/07/99 8:30 p.m.	78	0.6	118	126	134	2.0	1.5	124	124	1.8	1.8	132	118	2.0	3.0
09/08/99 3:00 a.m.	78	0.6	123	123	122	2.1	2.3	123	120	1.9	2.1	134	120	2.0	2.5
09/08/99 12:00 p.m.	79	0.6	120	120	125	2.2	2.0	120	120	1.8	1.8	135	135	2.0	1.5
09/08/99 7:00 p.m.	78	0.6	118	127	125	2.0	2.0	120	120	1.8	2.0	140	120	1.8	2.0

Date/Time	Incoming Water Temp °F	Ener -Tec DC Amps	Supply Steam PSIG	HE #1Water Temp °F		HE #1Flow Rate GPM		HE #2Water Temp °F		HE #2Flow Rate GPM		HE #3Water Temp °F		HE #3Flow Rate GPM	
				Mag	Ctrl	Mag	Ctrl	Mag	Ctrl	Mag	Ctrl	Elect	Ctrl	Elect	Ctrl
09/09/99 3:00 a.m.	78	0.6	124	126	125	2.0	1.9	121	119	1.9	2.0	131	122	1.9	2.0
09/09/99 10:00 a.m.	78	0.6	120	120	120	2.0	2.0	116	116	2.0	2.0	135	122	2.0	2.0
09/09/99* 11:45 a.m.	78	0.6	119	122	120	2.0	2.0	116	117	2.0	2.0	134	120	2.0	2.7
09/09/99 3:00 p.m.	78	0.6	106	143	134	2.0	2.0	136	143	2.0	2.0	140	148	2.0	2.0
09/09/99 5:30 p.m.	78	0.6	106	134	126	2.8	2.6	144	122	2.0	2.6	126	140	2.5	2.3
09/10/99 3:00 a.m.	78	0.6	108	125	126	2.7	2.6	144	121	1.7	2.4	124	139	2.3	2.1
09/10/99 12:30 p.m.	78	0.5	110	132	130	2.4	2.1	126	138	2.0	2.2	121	133	2.4	2.2
09/11/99 3:00 a.m.	77	0.6	116	131	129	2.2	2.0	136	123	2.2	2.1	122	133	2.2	2.1
09/11/99 11:00 a.m.	78	0.5	104	126	122	2.5	2.5	120	131	2.2	2.5	116	130	3.0	2.3
09/11/99 7:00 p.m.	77	0.5	112	127	124	2.1	2.3	122	136	2.0	2.3	120	135	2.8	2.0
09/12/99 3:00 a.m.	77	0.6	112	126	124	2.1	2.3	138	130	2.2	1.7	119	134	2.9	2.1
09/12/99 11:00 a.m.	77	0.5	118	128	127	2.0	2.0	122	136	2.0	2.0	121	136	2.0	2.0
09/12/99 7:00 p.m.	77	0.5	118	132	130	2.0	2.0	120	130	2.0	2.0	122	138	2.0	2.0
System down for repairs															
09/20/99 7:00 p.m.	73	0.6	118	116	114	1.5	1.5	120	119	1.4	1.3	123	122	1.2	1.2
09/21/99 3:00 a.m.	72	0.6	120	114	114	2.0	2.0	112	114	2.0	2.0	116	114	2.0	2.0
09/21/99 12:00 p.m.	71	0.5	122	115	116	1.5	1.5	115	114	1.7	1.7	120	122	1.5	1.5
Coupling Broke. Repairs made, water turned on 09/22/99 1:30 a.m.															
09/22/99* 3:00 a.m.	70	0.6	113	125	125	2.0	2.0	116	136	2.0	2.0	124	128	2.0	2.0
09/22/99 3:45 a.m.	70	0.6	113	126	124	2.0	2.1	112	134	2.3	1.9	124	160	2.0	1.0

* Water Samples collected. Note: 09/20/99 -Flow increased to +3 GPM at 4 p.m., then readjust to 2 GPM after water pressure is stable ~6 p.m.

Date/Time	Incoming Water Temp °F	Ener -Tec DC Amps	Supply Steam PSIG	HE #1Water Temp °F		HE #1Flow Rate GPM		HE #2Water Temp °F		HE #2Flow Rate GPM		HE #3Water Temp °F		HE #3Flow Rate GPM	
				Mag	Ctrl	Mag	Ctrl	Mag	Ctrl	Mag	Ctrl	Elect	Ctrl	Elect	Ctrl
09/22/99 7:00 p.m.	72	0.6	113	112	112	2.0	2.0	106	106	2.0	2.0	106	110	2.0	2.0
09/23/99 3:00 a.m.	71	0.6	114	110	112	2.1	2.2	115	114	2.0	2.1	114	115	2.0	2.0
09/23/99 11:00 p.m.	70	0.06	118	110	111	2.2	2.2	111	114	2.1	2.2	111	112	2.0	2.2
09/23/99 5:30 p.m.	70	0.06	118	112	113	2.0	2.0	113	116	2.2	1.6	111	114	2.0	1.9
09/27/99 2:15 p.m.	70	0.05	119	110	112	2.1	2.0	111	114	2.1	2.0	108	110	2.0	2.0
09/27/99 7:00 p.m.	71	0.05	120	115	120	1.8	1.8	116	119	1.8	1.6	117	118	1.5	1.6
09/28/99 2:30 a.m.	70	0.05	122	112	112	2.1	2.1	116	114	1.9	1.7	100	108	1.7	2.0
09/28/99 11:00 a.m.	69	0.05	120	106	108	2.2	2.2	112	110	2.0	2.5	107	110	2.1	2.0
09/28/99 7:00 p.m.	71	0.06	122	109	110	2.0	2.1	114	112	1.8	1.6	112	113	1.8	2.0
09/29/99 3:00 a.m.	70	0.06	120	108	109	2.1	2.2	108	110	3.0	2.1	106	108	2.0	2.2
09/29/99 11:00 a.m.	68	0.05	120	105	109	2.1	1.9	110	108	2.5	2.1	110	114	1.7	2.0
09/29/99 7:00 p.m.	70	0.06	123	108	111	2.0	2.1	110	112	2.2	2.0	112	116	1.8	1.6
09/30/99 3:00 a.m.	70	0.06	120	106	108	2.0	2.1	110	111	2.0	2.0	108	110	2.0	2.0
09/30/99 11:00 a.m.	68	0.6	126	111	112	1.8	1.8	112	113	1.9	1.8	114	115	1.9	1.9
09/30/99 7:00 p.m.	70	0.6	122	110	113	1.9	1.9	114	116	1.8	1.8	108	114	2.1	1.9
10/01/99 2:00 a.m.	70	0.6	124	110	112	1.9	1.9	115	116	1.7	1.8	108	114	2.0	1.9
10/01/99 *12:45 p.m.	68	0.6	123	102	106	2.0	2.0	106	106	2.0	2.0	106	108	2.0	2.0
10/01/99 1:10 p.m.	67	0.6	118	96	98	3.0	3.0	98	99	3.0	3.0	98	101	3.0	3.0
10/01/99 1:30 p.m.	68	0.6	122	103	106	2.0	2.0	106	107	2.0	2.0	106	106	2.0	2.0
10/01/99 7:00 p.m.	70	0.6	122	108	110	1.9	1.9	114	115	1.7	1.8	108	114	1.9	1.9
10/05/99 11:00 a.m.	66	0.5	127	110	110	2.0	2.1	110	112	3.0	2.1	109	108	1.9	2.1
10/05/99 7:00 p.m.	67	0.6	122	114	112	2.2	2.1	116	118	1.8	1.2	114	114	1.7	1.9
10/06/99 3:00 a.m.	66	0.6	118	104	118	2.2	2.2	110	104	2.0	2.1	107	109	1.9	2.0
10/06/99 11:00 a.m.	64	0.5	120	98	102	2.2	2.2	104	105	2.0	2.0	104	106	2.0	2.1
10/06/99 7:00 p.m.	66	0.6	122	100	106	2.1	2.0	112	106	2.0	2.0	107	108	2.0	2.0
10/07/99 12:00 p.m.	63	0.6	121	96	103	2.5	2.3	114	102	2.2	2.1	104	102	2.0	2.1

Date/Time	Incoming Water Temp °F	Ener -Tec DC Amps	Supply Steam PSIG	HE #1Water Temp °F		HE #1Flow Rate GPM		HE #2Water Temp °F		HE #2Flow Rate GPM		HE #3Water Temp °F		HE #3Flow Rate GPM	
				Mag	Ctrl	Mag	Ctrl	Mag	Ctrl	Mag	Ctrl	Elect	Ctrl	Elect	Ctrl
10/07/99 7:00 p.m.	63	0.6	121	104	108	2.0	2.1	116	108	2.2	1.9	110	110	1.9	1.8
10/08/99 3:00 a.m.	63	0.6	124	102	106	2.0	2.0	112	107	1.8	1.9	109	108	1.8	1.7
10/08/99* 12:00 p.m.	62	0.6	122	101	106	2.0	2.0	102	108	2.0	2.0	102	102	2.0	2.0
10/08/99 12:40 p.m.	62	0.6	122	102	108	2.0	2.0	101	107	2.0	2.0	102	102	2.0	2.0
10/08/99 12:50 p.m.	62	0.6	114	94	98	3.0	3.0	92	95	3.0	3.0	94	93	3.0	3.0
10/08/99 1:00 p.m.	62	0.6	121	106	110	2.0	2.0	102	106	2.0	2.0	102	100	2.0	2.0
10/08/99 7:00 p.m.	63	0.6	122	112	114	1.8	1.9	114	110	1.9	1.8	106	104	1.9	1.9
10/09/99 3:00 a.m.	66	0.6	122	114	114	1.7	1.8	114	108	1.9	1.8	105	104	1.9	1.9
10/09/99 11:00 a.m.	64	0.6	122	108	110	1.8	2.0	100	110	2.0	1.9	100	100	2.0	2.0
10/09/99 7:00 p.m.	63	0.6	224	114	116	1.5	1.9	120	108	1.2	1.8	106	104	1.9	1.9
10/10/99 3:00 a.m.	63	0.6	123	108	112	1.5	1.9	114	102	2.0	1.9	104	102	2.1	2.0
10/10/99 11:00 a.m.	63	0.6	124	106	110	1.5	2.0	110	100	2.0	1.8	100	100	2.0	2.0
10/10/99 7:00 p.m.	63	0.6	126	114	117	1.3	2.0	120	106	1.4	1.6	106	104	2.0	2.0
10/11/99 3:00 a.m.	63	0.6	122	106	120	2.0	1.6	102	100	2.1	2.0	106	104	1.9	1.9
10/11/99 11:00 a.m.	63	0.6	122	100	112	2.2	2.0	112	100	2.5	2.5	100	100	2.0	2.0
10/11/99 7:00 p.m.	64	0.6	124	100	112	2.1	2.0	98	96	1.8	1.6	102	100	2.0	2.0
10/12/99 3:00 a.m.	64	0.6	121	104	110	2.0	1.9	98	98	1.9	1.8	103	101	2.0	1.9
10/12/99 11:00 a.m.	63	0.6	124	101	112	2.5	2.0	92	90	2.8	3.0	100	100	2.0	2.0
10/12/99 7:00 p.m.	63	0.6	122	108	124	1.8	1.8	94	94	2.5	2.3	108	106	1.8	1.7
10/13/99 3:00 a.m.	65	0.6	122	100	106	2.2	2.2	101	100	1.8	1.9	101	101	2.0	1.9

* Water samples collected.

Date/Time	Incoming Water Temp °F	Ener -Tec DC Amps	Steam PSIG	HE #1Water Temp °F		HE #1Flow Rate GPM		HE #2Water Temp °F		HE #2Flow Rate GPM		HE #3Water Temp °F		HE #3Flow Rate GPM	
				Mag	Ctrl	Mag	Ctrl	Mag	Ctrl	Mag		Elect	Ctrl	Elect	Ctrl
10/13/99 11:00 a.m.	64	0.6	122	98	103	2.5	2.5	100	104	2.1	2.0	98	98	2.1	2.0
10/13/99 7:00 p.m.	63	0.6	124	96	102	2.3	2.2	108	104	1.9	2.0	103	102	2.0	2.0
10/14/99 3:00 a.m.	64	0.6	124	101	121	2.0	2.1	103	100	2.0	2.0	101	100	2.0	2.0
10/14/99 11:00 a.m.	62	0.6	122	100	114	2.2	1.8	100	97	2.1	2.1	98	97	2.0	2.0
10/14/99 7:00 p.m.	63	0.6	124	104	108	1.9	1.9	108	106	1.9	1.9	102	102	1.9	1.9
10/15/99 3:00 a.m.	64	0.6	124	104	107	1.9	1.8	108	102	1.9	1.9	101	100	2.0	2.0
10/15/99 12:50 p.m.	64	0.6	124	100	108	2.0	2.0	100	102	2.0	2.0	100	98	2.0	2.0
10/15/99* 11:25 a.m.	64	0.6	124	102	108	2.0	2.0	101	104	2.0	2.0	100	98	2.0	2.0
10/15/99 12:20 p.m.	64	0.6	117	94	98	3.0	3.0	92	94	3.0	3.0	92	90	3.0	3.0
10/16/99 3:00 a.m.	66	0.6	126	108	114	2.0	2.0	107	102	1.8	1.9	104	102	1.8	1.8
10/16/99 11:00 a.m.	64	0.6	124	100	106	2.4	2.0	102	100	2.1	2.1	100	100	2.0	2.0
10/16/99 7:00 p.m.	63	0.6	126	100	112	2.0	2.0	108	104	1.9	1.9	104	102	1.8	1.8
10/17/99 3:00 a.m.	66	0.6	128	99	108	2.1	2.0	106	103	1.9	1.9	104	102	1.9	1.8
10/17/99 7:00 a.m.	64	0.6	124	98	104	2.3	2.0	100	102	2.0	2.0	100	100	2.0	2.0
10/17/99 7:00 p.m.	63	0.6	126	100	112	2.0	1.8	108	104	1.9	1.8	103	104	2.0	2.0
10/18/99 3:00 a.m.	62	0.6	123	96	102	2.0	2.0	100	96	2.0	2.0	100	98	1.9	1.9
10/18/99 11:00 a.m.	63	0.6	124	98	102	2.2	2.2	96	98	2.1	2.3	98	98	2.0	2.0
10/18/99 7:00 p.m.	64	0.6	126	98	104	2.0	2.0	102	100	2.0	2.1	102	100	1.8	1.9
10/19/99 3:00 a.m.	62	0.6	126	100	108	2.0	2.0	104	102	1.9	1.9	102	102	1.8	1.8
10/19/99 11:00 a.m.	63	0.6	126	98	104	2.0	2.1	98	100	2.1	2.1	98	98	1.9	1.9

* Water samples collected.

Date/Time	Incoming Water Temp °F	Ener -Tec DC Amps	Steam PSIG	HE #1Water Temp °F		HE #1Flow Rate GPM		HE #2Water Temp °F		HE #2Flow Rate GPM		HE #3Water Temp °F		HE #3Flow Rate GPM	
				Mag	Ctrl	Mag	Ctrl	Mag	Ctrl	Mag		Elect	Ctrl	Elect	Ctrl
10/19/99 7:00 p.m.	64	0.6	126	100	104	2.0	2.0	102	98	1.9	2.0	102	101	1.8	1.8
10/20/99 3:00 a.m.	64	0.6	126	100	110	2.0	2.0	102	100	2.0	2.0	100	98	1.9	1.9
10/20/99 11:00 a.m.	62	0.6	126	98	104	2.1	1.9	96	98	2.3	2.3	96	96	2.0	2.0
10/20/99 7:00 p.m.	64	0.6	126	100	108	2.0	1.8	102	100	2.0	2.1	100	99	2.0	1.9
10/21/99 3:00 a.m.	63	0.6	126	100	108	2.0	1.8	103	100	1.9	1.9	100	99	1.9	1.8
10/21/99 1:00 p.m.	61	0.6	125	97	102	2.0	2.0	96	100	2.0	2.0	96	95	2.0	2.0
10/21/99 5:00 p.m.	62	0.6	124	98	104	2.0	2.0	102	98	1.9	1.9	98	97	1.9	1.8
10/22/99 3:00 a.m.	61	0.6	127	96	101	2.0	2.0	100	96	1.9	2.0	97	96	2.0	1.9
10/22/99 2:00 p.m.	61	0.6	124	96	101	2.0	2.2	94	96	2.4	2.2	96	94	2.0	2.0
10/22/99 7:00 p.m.	61	0.6	128	98	108	1.9	1.8	108	100	1.7	1.9	98	96	2.0	1.9
10/23/99 3:00 a.m.	62	0.6	124	96	104	1.9	1.8	106	98	1.8	1.9	100	98	2.0	1.8
10/23/99 7:00 p.m.	Steam Off/Tube Missing														
10/25/99 11:00 a.m.	60	0.6	118	100	100	2.2	2.5	98	98	2.0	2.2	104	98	2.0	2.1
10/25/99 7:00 p.m.	62	0.6	120	104	106	2.0	2.2	104	102	1.8	2.0	118	104	2.0	2.0
10/26/99 3:00 a.m.	62	0.6	120	108	112	2.0	2.0	102	101	1.9	2.0	117	103	2.0	1.8
10/26/99 11:00 a.m.	58	0.6	120	104	104	2.0	2.2	98	96	2.0	2.2	110	100	2.3	1.9
10/26/99 7:00 p.m.	60	0.6	120	106	110	1.9	2.0	98	96	1.9	2.0	116	102	2.1	1.8
10/27/99 3:15 a.m.	62	0.6	123	110	112	1.9	1.8	100	98	2.0	1.9	118	100	2.1	2.0
10/27/99 11:00 a.m.	59	0.6	120	102	106	2.0	1.9	92	94	2.2	2.0	110	96	2.2	2.1
10/27/99 7:00 p.m.	61	0.6	120	110	114	1.8	1.5	100	98	1.9	2.0	118	100	2.0	2.0
10/28/99 3:00 a.m.	60	0.6	120	100	102	2.0	2.1	94	96	2.0	2.0	114	98	2.1	2.0
10/28/99 10:50 a.m.	56	0.6	120	98	100	2.0	2.0	92	91	2.0	2.1	116	94	2.0	2.0
10/28/99 7:00 p.m.	60	0.6	124	106	110	1.9	1.9	98	98	1.9	1.9	120	98	1.8	1.9
10/29/99 3:00 a.m.	60	0.6	124	106	108	1.9	1.8	98	98	1.9	1.9	120	98	1.8	1.9
10/29/99 11:00 a.m.	58	0.6	122	96	100	2.0	2.0	90	90	2.0	2.0	111	100	2.0	2.0
10/29/99 7:00 p.m.	60	0.6	124	98	102	2.0	2.0	96	96	1.9	1.8	114	102	1.9	2.0

Date/Time	Incoming Water Temp °F	Ener -Tec DC Amps	Steam PSIG	HE #1Water Temp °F		HE #1Flow Rate GPM		HE #2Water Temp °F		HE #2Flow Rate GPM		HE #3Water Temp °F		HE #3Flow Rate GPM	
				Mag	Ctrl	Mag	Ctrl	Mag	Ctrl	Mag		Elect	Ctrl	Elect	Ctrl
10/30/99 3:00 a.m.	58	0.6	122	98	102	2.0	2.0	92	92	2.0	2.0	118	96	1.9	2.0
10/30/99 11:00 a.m.	58	0.6	121	98	100	2.4	2.0	90	90	2.3	2.1	117	94	1.9	2.1
10/30/99 7:00 p.m.	58	0.6	124	102	106	2.0	1.8	92	93	2.0	2.0	122	96	1.8	1.9
10/31/99 3:00 a.m.	60	0.6	124	105	110	2.0	1.8	95	95	1.9	1.9	128	98	2.0	1.9
10/31/99 11:00 a.m.	58	0.6	122	100	104	2.1	2.0	92	90	2.1	2.1	106	98	2.3	1.8
10/31/99 7:00 p.m.	60	0.6	124	118	122	1.6	1.7	104	104	1.8	1.8	122	116	2.0	1.6
11/01/99 3:00 a.m.	58	0.6	120	90	90	2.8	3.0	88	90	2.3	2.3	110	96	2.1	1.9
11/01/99 11:00 a.m.	58	0.6	122	102	104	2.0	2.0	90	92	2.0	2.0	106	94	2.4	2.0
11/01/99 7:00 p.m.	60	0.6	124	113	112	1.6	1.9	96	98	2.0	2.0	116	100	2.1	2.0
11/02/99 3:00 a.m.	62	0.6	124	92	106	3.0	2.0	96	98	1.9	1.9	120	100	1.9	1.7
11/02/99* 9:30 a.m.	58	0.6	122	103	104	2.0	2.0	92	92	2.0	2.0	112	92	2.0	2.0
11/02/99 10:10 a.m.	58	0.6	123	102	104	2.0	2.0	92	91	2.0	2.0	112	92	2.0	2.0
11/02/99 10:25 a.m.	58	0.6	117	90	93	3.0	3.0	85	84	3.0	3.0	98	85	3.0	2.8
11/02/99 10:40 a.m.	58	0.6	124	100	104	2.0	2.0	92	92	2.0	2.0	111	91	2.0	2.0
11/02/99* 11:10 a.m.	57	0.0	0	56	59	3.0	3.0	57	57	3.0	3.0	57	58	3.0	3.0
* 11/02/99	Shutdown														

* Water samples collected.

* Water samples collected.

Table D4. Water analyses (09 September 1999).

09/09/99	Cold Distribution	Heat Exchanger #1		Heat Exchanger #2		Heat Exchanger #3	
		Magnetic	Control	Magnetic	Control	Electronic	Control
M Alkalinity (mg/L as CaCO ₃)	134	138	134	136	138	138	136
Hardness (mg/L as CaCO ₃)	207.8	206.7	207.8	208.5	210.0	206.3	211.4
Calcium (mg/L as Ca)	55.10	56.10	55.10	55.20	55.60	55.30	56.00
Magnesium (mg/L as Mg)	16.30	16.60	16.30	16.40	16.50	17.00	16.60
Sulfate (mg/L as SO ₄)	57	59	58	58	57	57	59
Chloride (mg/L as Cl)	24	24	25	24	23	23	22
Nitrate (mg/L as NO ₃)	6.7	6.7	6.7	6.8	6.7	6.6	6.6
Iron (mg/L as Fe)	0.00	0.00	0.01	0.00	0.00	0.01	0.00
Copper (mg/L as Cu)	0.00	0.00	0.00	0.00	0.00	0.00	0.00
Zinc (mg/L as Zn)	0.00	0.00	0.00	0.00	0.00	0.00	0.00
Sodium (mg/L as Na)	10.3	10.6	10.4	10.5	10.5	10.6	10.6
Manganese (mg/L Mn)	0.004	0.006	<0.003	0.005	0.005	0.004	<0.003
Total Dissolved Solids (mg/L)	276	274	278	270	273	278	274
pH	7.69	7.66	7.66	7.64	7.76	7.63	7.72
Sample Temperature (°C)	27.2	37.1	36.4	35.6	34.3	37.7	34.1
Silica (mg/L as SiO ₂)	9.3	9.4	9.2	9.3	9.3	9.3	9.3
Ammonia (mg/L as NH ₄)	4.0	3.7	4.1	3.3	4.1	4.0	3.9
Conductivity (µS/cm)	454	457	459	457	458	454	457

Table D5. Water sample analyses (22 September 1099).

09/22/99	Cold Distribution	Heat Exchanger #1		Heat Exchanger #2		Heat Exchanger #3	
		Magnetic	Control	Magnetic	Control	Electronic	Control
M Alkalinity (mg/L as CaCO ₃)	140	138	138	138	138	138	138
Hardness (mg/L as CaCO ₃)	220.1	215.4	216.6	211.0	216.6	218.4	217.2
Calcium (mg/L as Ca)	56.20	54.50	54.80	55.50	54.80	55.70	55.40
Magnesium (mg/L as Mg)	18.50	18.40	18.50	18.30	18.50	18.40	18.30
Sulfate (mg/L as SO ₄)	52	49	49	53	50	51	52
Chloride (mg/L as Cl)	35	35	36	35	36	35	35
Nitrate (mg/L as NO ₃)	6.5	6.5	6.5	6.4	6.5	6.4	6.4
Iron (mg/L as Fe)	0.00	0.00	0.00	0.00	0.00	0.00	0.00
Copper (mg/L as Cu)	0.03	0.05	0.00	0.01	0.00	0.00	0.01
Zinc (mg/L as Zn)	0.00	0.00	0.00	0.00	0.00	0.00	0.00
Sodium (mg/L as Na)	10.7	9.9	9.9	10.6	10.1	10.6	10.7
Manganese (mg/L as Mn)	0.006	0.005	0.005	0.006	0.005	0.005	0.007
Total Dissolved Solids (mg/L)	313	315	325	323	312	313	317
pH	7.64	7.58	7.57	7.70	7.60	7.60	7.63
Sample Temperature (C)	22.1	53.1	49.4	41.1	54.0	51.3	49.8
Silica (mg/L as SiO ₂)	9.2	8.9	9.0	9.1	8.9	9.1	9.1
Ammonia (mg/L as NH ₄)	8.1	4.9	7.7	5.0	4.8	4.6	5.7
Conductivity (μS/cm)	505	473	472	476	473	477	475

Table D6. Water sample analyses (01 October 1999).

10/01/99	Cold Distribution	Heat Exchanger #1		Heat Exchanger #2		Heat Exchanger #3	
		Magnetic	Control	Magnetic	Control	Electronic	Control
M Alkalinity (mg/L as CaCO ₃)	136	136	134	140	136	134	136
Hardness (mg/L as CaCO ₃)	213.6	209.3	212.6	211.0	211.4	214.9	210.5
Calcium (mg/L as Ca)	53.80	52.60	53.40	53.10	53.10	55.00	52.90
Magnesium (mg/L as Mg)	18.40	18.10	18.40	18.20	18.30	18.00	18.20
Sulfate (mg/L as SO ₄)	48	47	46	47	48	49	48
Chloride (mg/L as Cl)	31	33	33	33	30	30	32
Nitrate (mg/L as NO ₃)	6.3	6.5	6.4	6.1	6.3	5.6	6.3
Iron (mg/L as Fe)	0.00	0.00	0.00	0.00	0.00	0.00	0.00
Copper (mg/L as Cu)	0.01	0.00	0.00	0.00	0.00	0.00	0.00
Zinc (mg/L as Zn)	0.00	0.00	0.00	0.00	0.00	0.00	0.00
Sodium (mg/L as Na)	10.7	10.1	10.5	10.1	10.3	10.8	10.1
Manganese (mg/L as Mn)	0.005	0.005	0.006	0.005	0.006	0.004	0.005
Total Dissolved Solids (mg/L)	270	323	266	315	266	246	260
pH	7.71	7.68	7.73	7.79	7.74	7.74	7.74
Sample Temperature (°C)	20.6	38.5	39.5	36.9	41.1	41.4	42.4
Silica (mg/L as SiO ₂)	7.3	7.2	7.4	7.3	7.3	7.7	7.3
Ammonia (mg/L as NH ₄)	6.8	8.7	5.7	4.1	5.3	4.4	5.3
Conductivity (μS/cm)	517	463	461	482	460	462	467

Table D7. Water sample analyses (08 October 1999).

10/08/99	Cold Distribution	Heat Exchanger #1		Heat Exchanger #2		Heat Exchanger #3	
		Magnetic	Control	Magnetic	Control	Electronic	Control
M Alkalinity (mg/L as CaCO ₃)	144	142	142	142	144	142	144
Hardness (mg/L as CaCO ₃)	224.2	225.5	220.8	239.2	223.4	236.8	224.1
Calcium (mg/L as Ca)	57.50	57.70	56.50	62.50	57.20	61.70	57.30
Magnesium (mg/L as Mg)	18.70	18.90	18.50	19.30	18.70	19.20	18.80
Sulfate (mg/L as SO ₄)	50	50	48	57	50	61	52
Chloride (mg/L as Cl)	32	31	29	32	29	32	30
Nitrate (mg/L as NO ₃)	6.2	6.1	6.0	6.1	6.0	6.0	6.0
Iron (mg/L as Fe)	0.00	0.02	0.06	0.00	0.00	0.00	0.00
Copper (mg/L as Cu)	0.00	0.00	0.02	0.00	0.00	0.00	0.00
Zinc (mg/L as Zn)	0.00	0.00	0.00	0.00	0.00	0.00	0.00
Sodium (mg/L as Na)	11.3	11.7	11.1	12.1	11.3	12.7	11.2
Manganese (mg/L as Mn)	0.006	0.006	0.007	0.005	0.005	0.006	0.005
Total Dissolved Solids (mg/L)	265	270	282	268	286	264	282
pH	7.72	7.75	7.75	7.77	7.75	7.76	7.78
Sample Temperature (°C)	17.7	37.9	39.8	36.5	42.2	39.3	38.3
Silica (mg/L as SiO ₂)	7.7	7.9	7.7	8.6	7.8	8.6	7.8
Ammonia (mg/L as NH ₄)	4.6	5.1	4.6	9.2	4.7	8.3	4.5
Conductivity (μS/cm)	544	479	483	482	482	479	486

Table D8. Water sample analyses (15 October 1999).

	Cold Distribution	Heat Exchanger #1		Heat Exchanger #2		Heat Exchanger #3	
		Magnetic	Control	Magnetic	Control	Electronic	Control
M Alkalinity (mg/L as CaCO ₃)	142	142	142	140	144	144	142
Hardness (mg/L as CaCO ₃)	220.9	215.3	222.3	218.6	222.1	221.8	217.6
Calcium (mg/L as Ca)	56.20	54.80	56.60	55.60	56.50	56.40	55.40
Magnesium (mg/L as Mg)	18.70	18.20	18.80	18.50	18.80	18.80	18.40
Sulfate (mg/L as SO ₄)	55	52	54	53	51	53	55
Chloride (mg/L as Cl)	26	22	27	25	28	26	28
Nitrate (mg/L as NO ₃)	6.1	5.9	6.1	6.0	6.0	6.0	5.9
Iron (mg/L as Fe)	0.00	0.01	0.00	0.00	0.00	0.00	0.00
Copper (mg/L as Cu)	0.00	0.00	0.00	0.00	0.00	0.00	0.00
Zinc (mg/L as Zn)	0.00	0.00	0.00	0.00	0.00	0.00	0.01
Sodium (mg/L as Na)	10.9	10.6	11.0	10.7	11.2	11.0	11.0
Manganese (mg/L as Mn)	0.005	0.004	0.005	0.005	0.006	0.005	0.006
Total Dissolved Solids (mg/L)	282	280	286	280	276	277	281
pH	7.86	7.65	7.67	7.68	7.65	7.66	7.69
Sample Temperature (°C)	17.7	38.5	38.9	35.5	38.8	37.1	36.0
Silica (mg/L as SiO ₂)	7.8	7.7	7.9	7.9	8.0	7.9	7.8
Ammonia (mg/L as NH ₄)	4.0	3.9	3.4	3.5	3.7	3.8	3.7
Conductivity (µS/cm)	476	475	474	476	475	475	475

Table D9. Water sample analyses (11 November 1999).

	Cold Distribution	Heat Exchanger #1		Heat Exchanger #2		Heat Exchanger #3	
		Magnetic	Control	Magnetic	Control	Electronic	Control
M Alkalinity (mg/L as CaCO ₃)	148	148	146	148	146	146	148
Hardness (mg/L as CaCO ₃)	198.0	201.7	201.9	201.9	201.2	200.7	203.1
Calcium (mg/L as Ca)	50.20	51.00	51.10	51.10	51.00	50.80	51.40
Magnesium (mg/L as Mg)	17.60	18.00	18.00	18.00	17.90	17.90	18.10
Sulfate (mg/L as SO ₄)	46	47	46	48	48	47	48
Chloride (mg/L as Cl)	25	26	26	25	25	25	26
Nitrate (mg/L as NO ₃)	6.0	5.9	5.9	5.9	5.9	5.9	5.9
Iron (mg/L as Fe)	0.03	0.00	0.00	0.00	0.03	0.00	0.00
Copper (mg/L as Cu)	0.00	0.00	0.00	0.00	0.00	0.00	0.00
Zinc (mg/L as Zn)	0.00	0.00	0.00	0.00	0.00	0.00	0.00
Sodium (mg/L as Na)	12.0	11.9	11.7	11.7	11.5	12.1	11.7
Manganese (mg/L as Mn)	0.008	0.008	0.009	0.008	0.008	0.007	0.008
Total Dissolved Solids (mg/L)	258	268	258	260	260	265	271
pH	7.71	7.65	7.62	7.72	7.71	7.65	7.71
Sample Temperature (°C)	15.1	38.7	38.6	31.5	33.2	42.8	33.3
Silica (mg/L as SiO ₂)	7.1	7.3	7.2	7.2	7.2	7.3	7.3
Ammonia (mg/L as NH ₄)	2.3	2.6	2.4	2.6	2.6	2.5	2.4
Conductivity (µS/cm)	472	472	472	472	470	472	476

Table D10. Corrosion coupon data.

Location	Serial Number	Initial Wt. (grams.)	Final Wt. (grams.)	Wt. Loss (grams)	MMPY	Installed	Removed
Control Cold Dist.	H4550	12.8439	12.8070	0.0369	0.449	09/03/99	11/02/99
1-M Before Heat Exchanger	H4551	12.8598	12.8319	0.0279	0.340	09/03/99	11/02/99
1-M After Heat Exchanger	G1554	13.0806	13.0473	0.0333	0.405	09/03/99	11/02/99
1-C After Heat Exchanger	G1555	13.0586	13.0327	0.0259	0.315	09/03/99	11/02/99
2-M Before Heat Exchanger	G1556	13.2002	13.1691	0.0311	0.379	09/03/99	11/02/99
2-M After Heat Exchanger	G1557	13.1373	13.1070	0.0303	0.369	09/03/99	11/02/99
2-C After Heat Exchanger	G1558	13.0920	13.0648	0.0272	0.331	09/03/99	11/02/99
3-M Before Heat Exchanger	G1559	13.1381	13.1066	0.0315	0.384	09/03/99	11/02/99
3-M After Heat Exchanger	G1560	13.0958	13.0603	0.0355	0.432	09/03/99	11/02/99
3-C After Heat Exchanger	G1561	13.1399	13.1109	0.0290	0.353	09/03/99	11/02/99

Table D11. Total scale removed.

Location	Loose: Mechanical Removal	Tight: Chemical Removal	Total from Copper Tube	Loose: After Exchanger*	Total from All
1M	1.973	0.942	2.915	2.072	4.987
1C	1.745	1.902	3.647	1.537	5.184
2M	2.254	6.032	8.286	0.098	8.384
2C	4.909	3.720	8.629	0.047	8.676
3M	4.062	1.085	5.147	4.071	9.218
3C	5.156	5.170	10.328	0.381	10.709

*Loose scale, found between the end of the heat exchanger and the flow meter.

Table D12. Calcium/magnesium ratio.

Element (as Moles)	1M	1C	2M	2C	3M	3C
Calcium (as CaO)	86	89	91	90	87	90
Magnesium (as MgO)	14	11	9	10	13	10
Note: Other elements were present as minor components.						

CERL Distribution

HQUSACE

ATTN: CEMP-RI (2)

Chief of Engineers

ATTN: CEHEC-IM-LH (2)

Engineer Research and Development Center (Libraries)

ATTN: ERDC, Vicksburg, MS

ATTN: Cold Regions Research, Hanover, NH

ATTN: Topographic Engineering Center, Alexandria, VA

Defense Tech Info Center 22304

ATTN: DTIC-O

8

5/01

